

ROBOTS5

ELECTRO-MECHANICAL BREADBOARD (EMB) AM4 USER MANUAL



Version 1.10 - Jan. 2023

ROBOTS5 LLC, USA



Disclaimer

- Be sure to read this document carefully and fully understand it, before using this product
- Be sure to read the “EMB Safety Document” carefully and fully understand it, before using this product
- Robots5 LLC is not responsible for any damage or injury caused by misuse, misunderstanding, or abuse of this product
- The user is solely responsible for the implementation of the controller and safety system used with EMB
- This document was generated and completed to the best ability of Robots5 LLC. The information on this manual are presented in good faith and believed to be correct however, Robots5 LLC makes no warranties as to the completeness or accuracy of the information
- Never use our products in any application where failure of the product could result in personal injury. Failure to comply with these instructions could result in death or serious injury
- This equipment should not be used by inexperienced users, unless if they are under close supervision of experienced users
- Robots5 LLC reserves the right to make changes to this document or to the products described herein without further notice
- Make sure to always use the latest version of this document

Contact Information:

Email: info@robots5.com

Website: www.robots5.com

Location: Melbourne, FL USA

© 2023 Robots5 LLC., All Rights Reserved.



Safety

- If improperly used, EMB can cause injury or death
- Never touch any moving parts! Always stay clear from gears, sprockets, belts, chains, linkages, and any components in motion
- Follow all information and recommendations from this document and from the “EMB Safety Document”
- Do not disassemble or modify this device
- Responsible use of EMB is crucial to prevent dangerous conditions
- Make sure to disconnect power when handling this device
- Only use this device in indoor applications, with no water/oil splash or contact. Never operate EMB near explosive gases or flammable liquids
- Treat this device with care, it is a precision unit. Do not throw, hit, or drop it
- If you notice the unit getting warm or hot or making abnormal noises or vibrations, or sense smoke immediately stop all motion and turn the power completely off. Assess the situation to understand the issue before attempting to resume operation
- Never stall the motor, this will damage the unit
- Do not operate outside the specifications of the unit
- Always have an effective way to cut power to the actuator, such as an emergency stop button (E-Stop). Check this feature before every use
- Always limit the actuator current to a safe level



Fingers may break or get amputated if caught in moving parts!

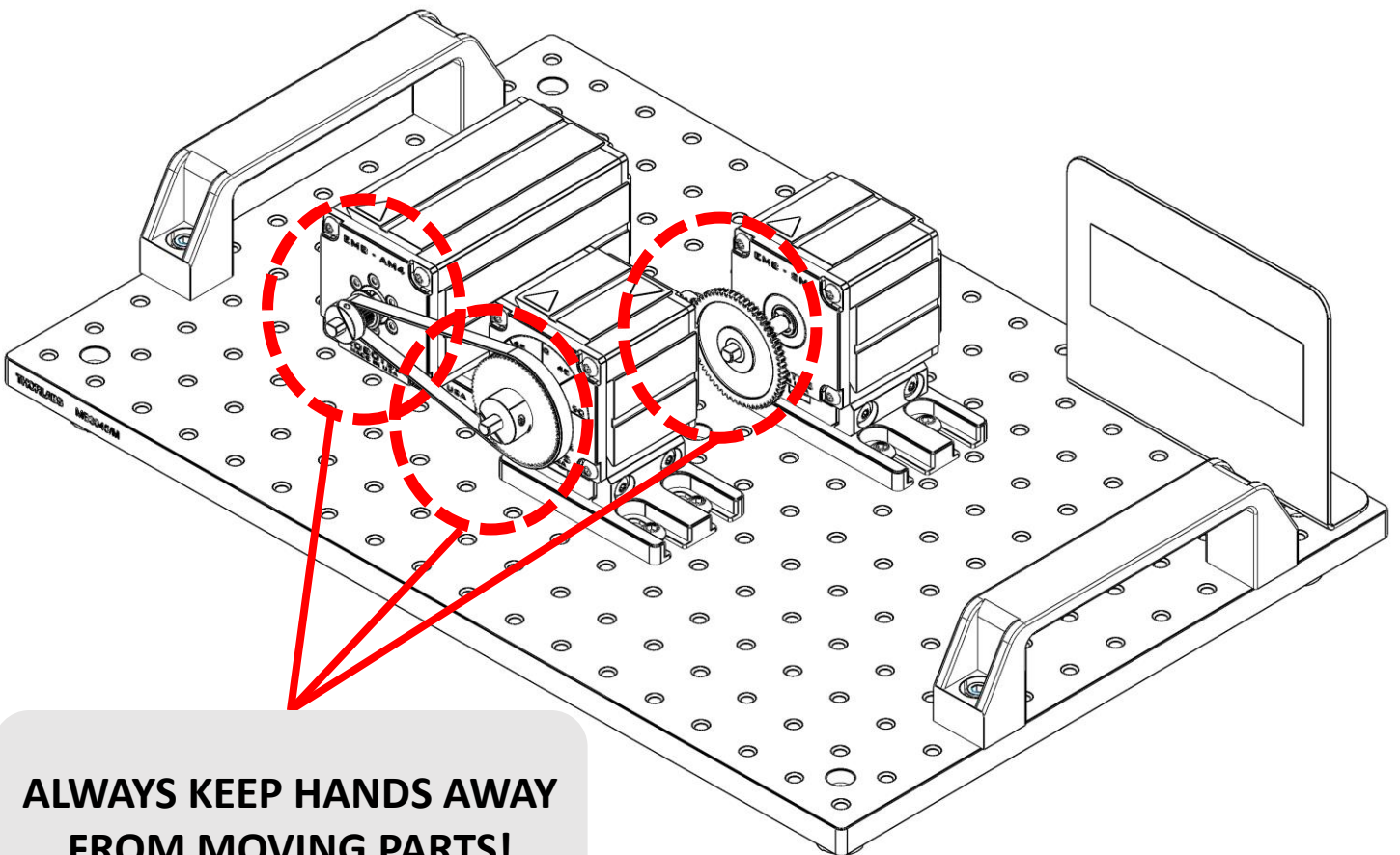

ALWAYS KEEP HANDS AWAY FROM MOVING PARTS!

Introduction

The EMB-AM4 is an actuator module, powered by a premium quality, high efficiency and low inductance brushed DC motor. There is no internal gearing, the system is direct drive.

This module is designed to interface with other EMB modules via components mounted to the drive shaft. Examples of components are gears, pulleys, sprockets, shaft coupler, and shaft collar hub.

The red anodized aluminum body of the EMB-AM4 module relies on a dovetail approach for precision locating and firmly securing to a dovetail rail, breadboard, or other modules or accessories.

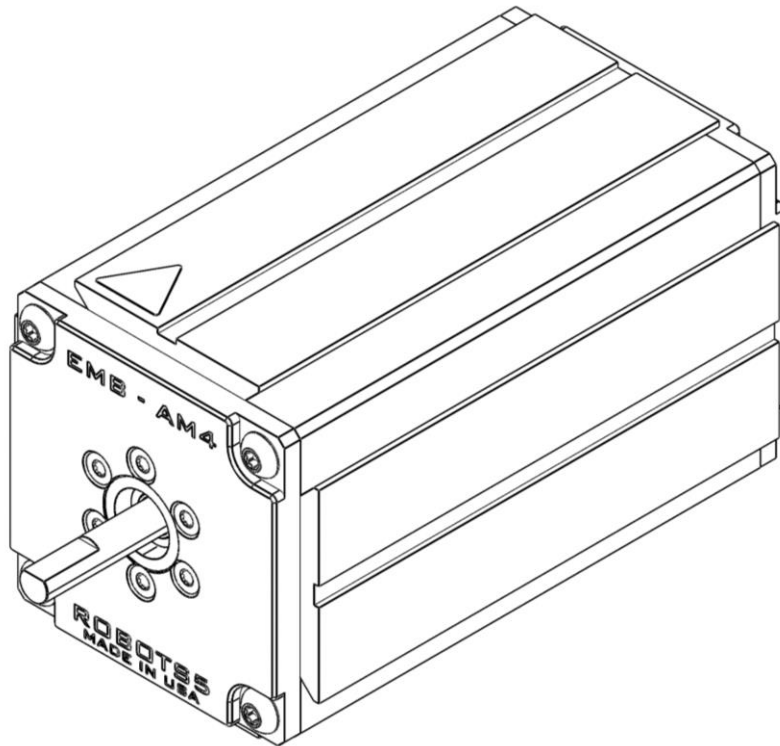

Figure 1: EMB-AM4 Module

The key features of the EMB-AM4 are presented bellow:

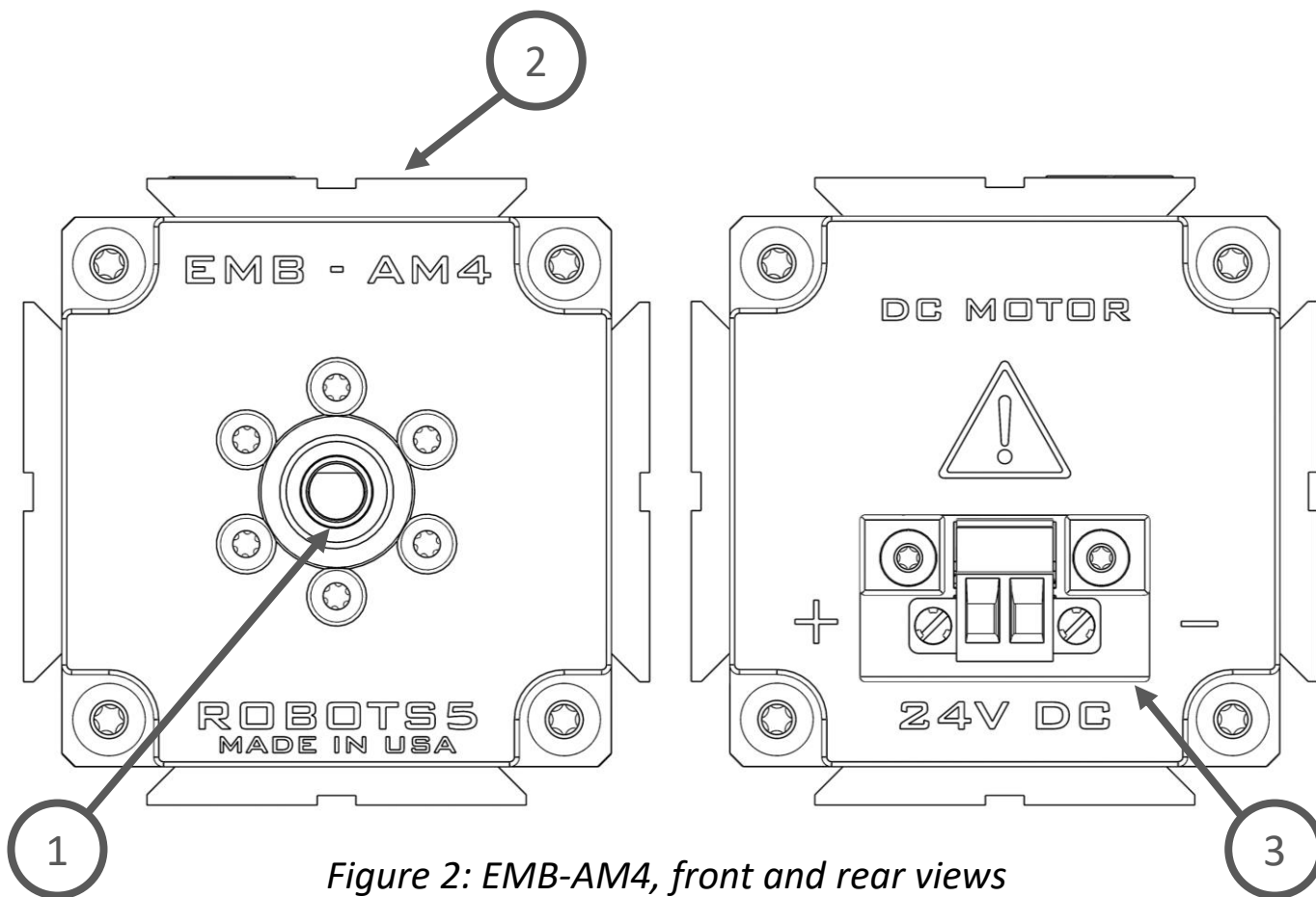

Figure 2: EMB-AM4, front and rear views

Item	Feature
1	Driving Shaft
2	Dovetail Mount, 4 sides
3	Phoenix Contact P# 0710170 Power Connector

Table 1: Key features of the EMB-AM4

Specifications

The EMB-AM4 module is powered by a custom maxon DCX32L brushed DC motor, with graphite brushes. Table 2 describes the motor data.

Although the nominal voltage of the motor is 24V, we strongly recommend keeping the speed under 4000 rpm, to keep EMB use safe.

Similarly, we strongly recommend limiting the current to a safe level. For general EMB use, 2A is a good start, assess if lowering or increasing this current limit is necessary for your experiment.

Motor Data		
1_	Nominal voltage	V 24
2_	No load speed	rpm 8270
3_	No load current	mA 164
4_	Nominal speed	rpm 7710
5_	Nominal torque (max. continuous torque)	mNm 108
6_	Nominal current (max. continuous current)	A 4.12
7_	Stall torque	mNm 1980
8_	Stall current	A 72.5
9_	Max. efficiency	% 88
10_	Terminal resistance	Ω 0.331
11_	Terminal inductance	mH 0.103
12_	Torque constant	mNm/A 27.3
13_	Speed constant	rpm/V 350
14_	Speed/torque gradient	rpm/mNm 4.24
15_	Mechanical time constant	ms 3.24
16_	Rotor inertia	gcm ² 72.8

Table 2: maxon DCX32L motor data, from maxon

Table 3 describes thermal data, mechanical data ball bearings, and other specifications:

Thermal data			
17_	Thermal resistance housing-ambient	K/W	7.28
18_	Thermal resistance winding-housing	K/W	2.3
19_	Thermal time constant winding	s	42.2
20_	Thermal time constant motor	s	837
21_	Ambient temperature	°C	-40...+100
22_	Max. winding temperature	°C	155
Mechanical data ball bearings			
23_	Max. speed	rpm	11 300
24_	Axial play	mm	0...0.1
	Preload	N	7
25_	Radial play	mm	0.02
26_	Max. axial load (dynamic)	N	7
27_	Max. force for press fits (static)	N	22.6
	(static, shaft supported)	N	2510
28_	Max. radial load [mm from flange]	N	65.3 [5]
Other specifications			
29_	Number of pole pairs		1
30_	Number of commutator segments		11
31_	Weight of motor	g	325
32_	Typical noise level	dBA	47

Table 3: maxon DCX32L additional motor data, from maxon

The weight of the module is 0.850 kg.

Figure 3, shows the general dimensions of the module:

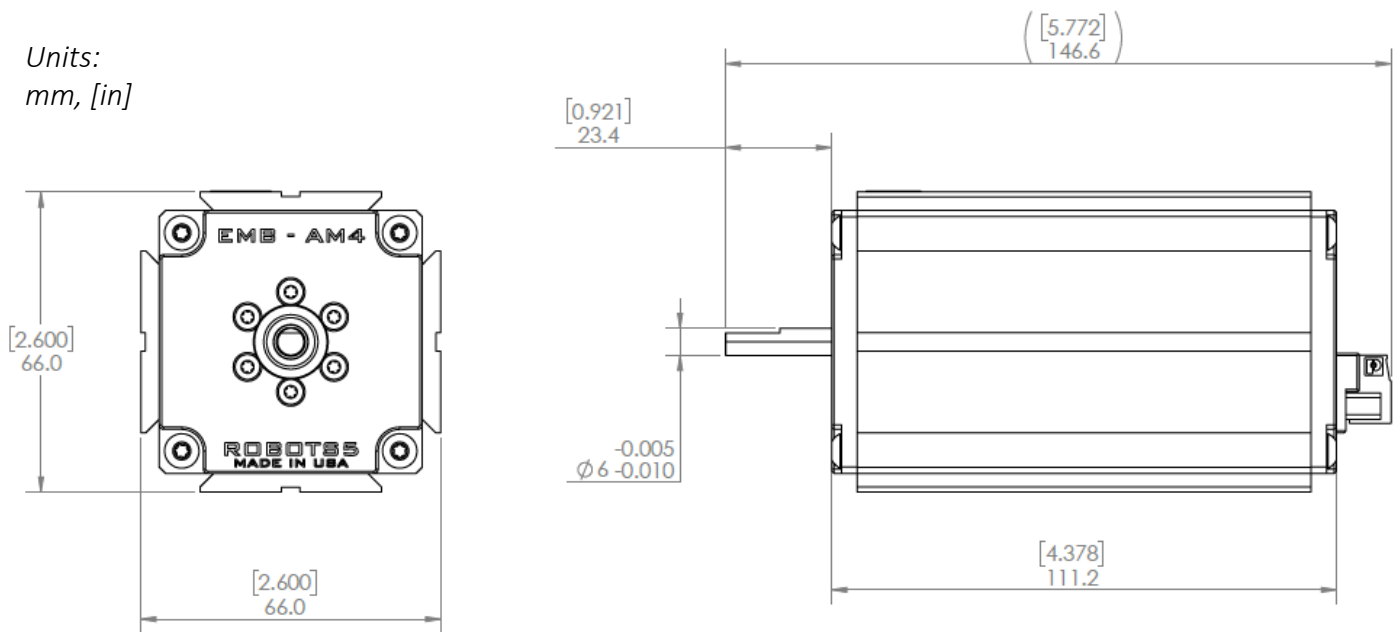

Figure 3: EMB-AM4, general dimensions

Note the shaft tolerance. Never press fit components to the shaft.

The dovetail profile matches the XT66 66mm optical construction rails from Thorlabs.

There are several mounting options to interface with the dovetail, including XT66C4, XT66C2, and XT66P3 from Thorlabs.

The power connector is a Phoenix Contact P# 0710170 (installed in the module).

The pin definition of power connect is indicated by “+” and “-”.

Our standard mating connector offering is the Phoenix Contact P# 1777989, but there are additional matting connectors available such as the 1777808 and 1834903.

For the electrical connections, we recommend the use of ferrule or solder dip to the wire leads. We discourage the use of bare wires into the terminal connector.

Have questions or need additional support?

Contact us at:

Web: www.robots5.com

Email: info@robots5.com

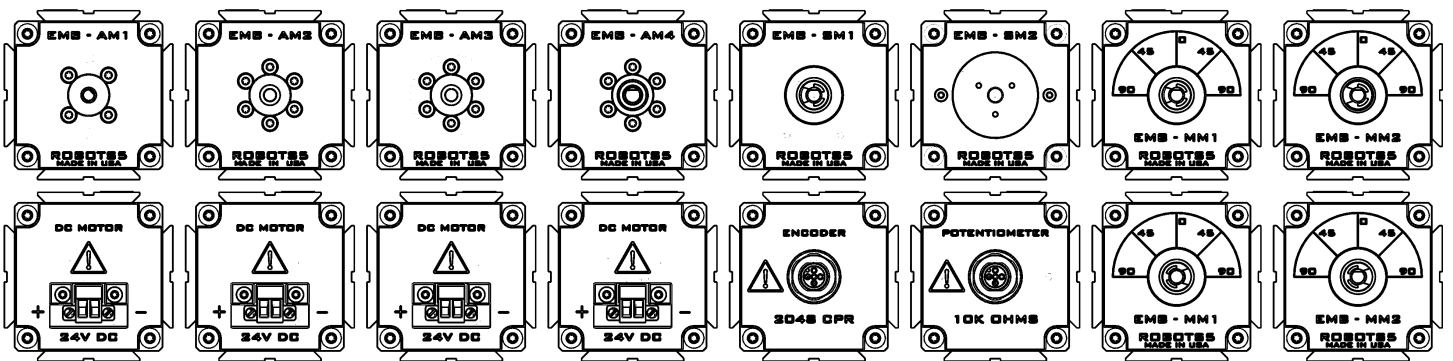

ROBOTS5