

# ROBOTS5

## ELECTRO-MECHANICAL BREADBOARD (EMB) IM1 USER MANUAL



Version 2.10 - Apr. 2024

ROBOTS5 LLC, USA



# Disclaimer

- Be sure to read this document carefully and fully understand it, before using this product
- Be sure to read the “EMB Safety Document” carefully and fully understand it, before using this product
- Robots5 LLC is not responsible for any damage or injury caused by misuse, misunderstanding, or abuse of this product
- The user is solely responsible for the implementation of the controller and safety system used with our products
- This document was generated and completed to the best ability of Robots5 LLC. The information on this manual are presented in good faith and believed to be correct however, Robots5 LLC makes no warranties as to the completeness or accuracy of the information
- Never use our products in any application where failure of the product could result in personal injury. Failure to comply with these instructions could result in death or serious injury
- This equipment should not be used by inexperienced users, unless if they are under close supervision of experienced users. Safety operation must be ensured by experienced users
- Robots5 LLC reserves the right to make changes to this document or to the products described herein without further notice
- Make sure to always use the latest version of this document

## **Contact Information:**

Email: [info@robots5.com](mailto:info@robots5.com)

Website: [www.robots5.com](http://www.robots5.com)

Location: Melbourne, FL USA

© 2024 Robots5 LLC., All Rights Reserved.



# Safety

- If improperly used, EMB can cause injury or death
- Never touch any moving parts! Always stay clear from gears, sprockets, belts, chains, linkages, and any components in motion
- Follow all information and recommendations from this document and from the “EMB Safety Document”
- Do not disassemble or modify this device
- Responsible use of EMB is crucial to prevent dangerous conditions
- Make sure to disconnect power when handling this device
- Only use this device in indoor applications, with no water/oil splash or contact. Never operate EMB near explosive gases or flammable liquids
- Treat this device with care, it is a precision unit. Do not throw, hit, or drop it
- If you notice the unit getting warm or hot or making abnormal noises or vibrations, or sense smoke, immediately stop all motion and turn the power completely off. Assess the situation to completely understand the issue before attempting to resume operation
- Never hot-plug this module, turn off power before plugging it in or off
- Do not operate outside the specifications of the unit
- Powering this device outside the electrical rating will damage it



**Fingers may break or get amputated if caught in moving parts!**

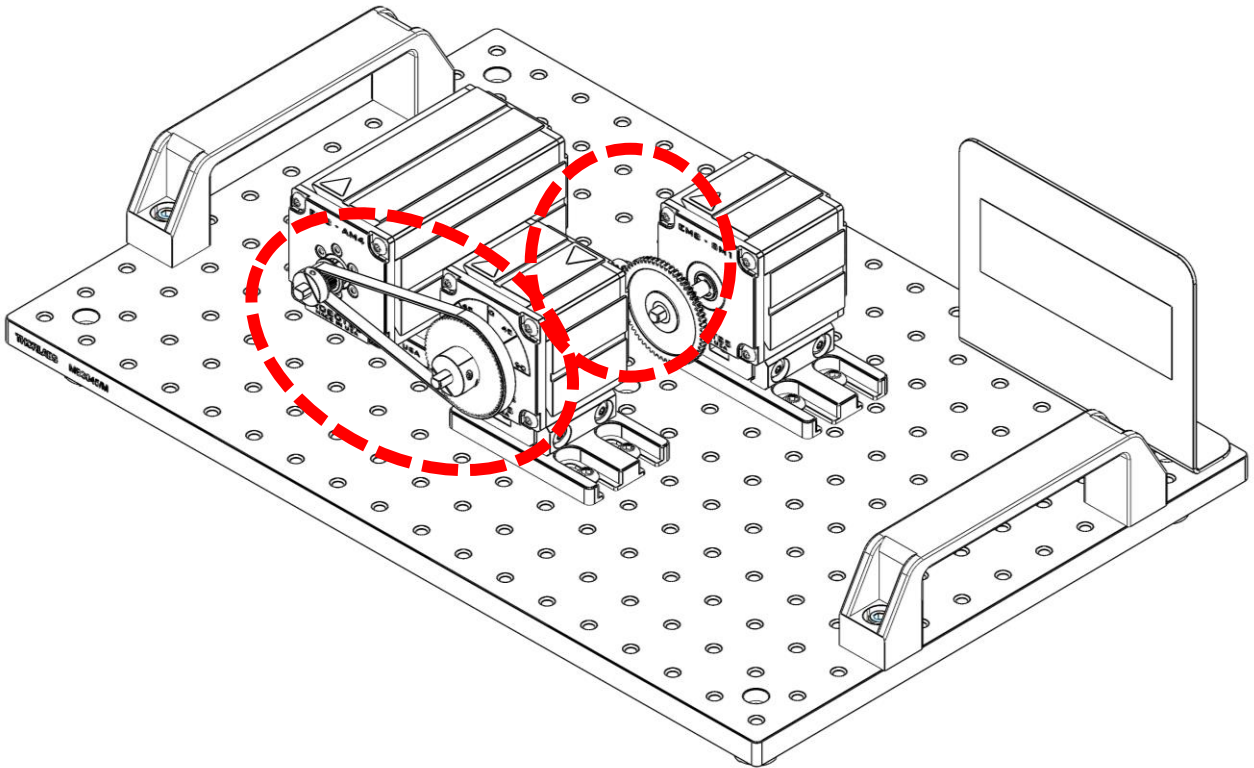

**ALWAYS KEEP HANDS AWAY FROM MOVING PARTS!**

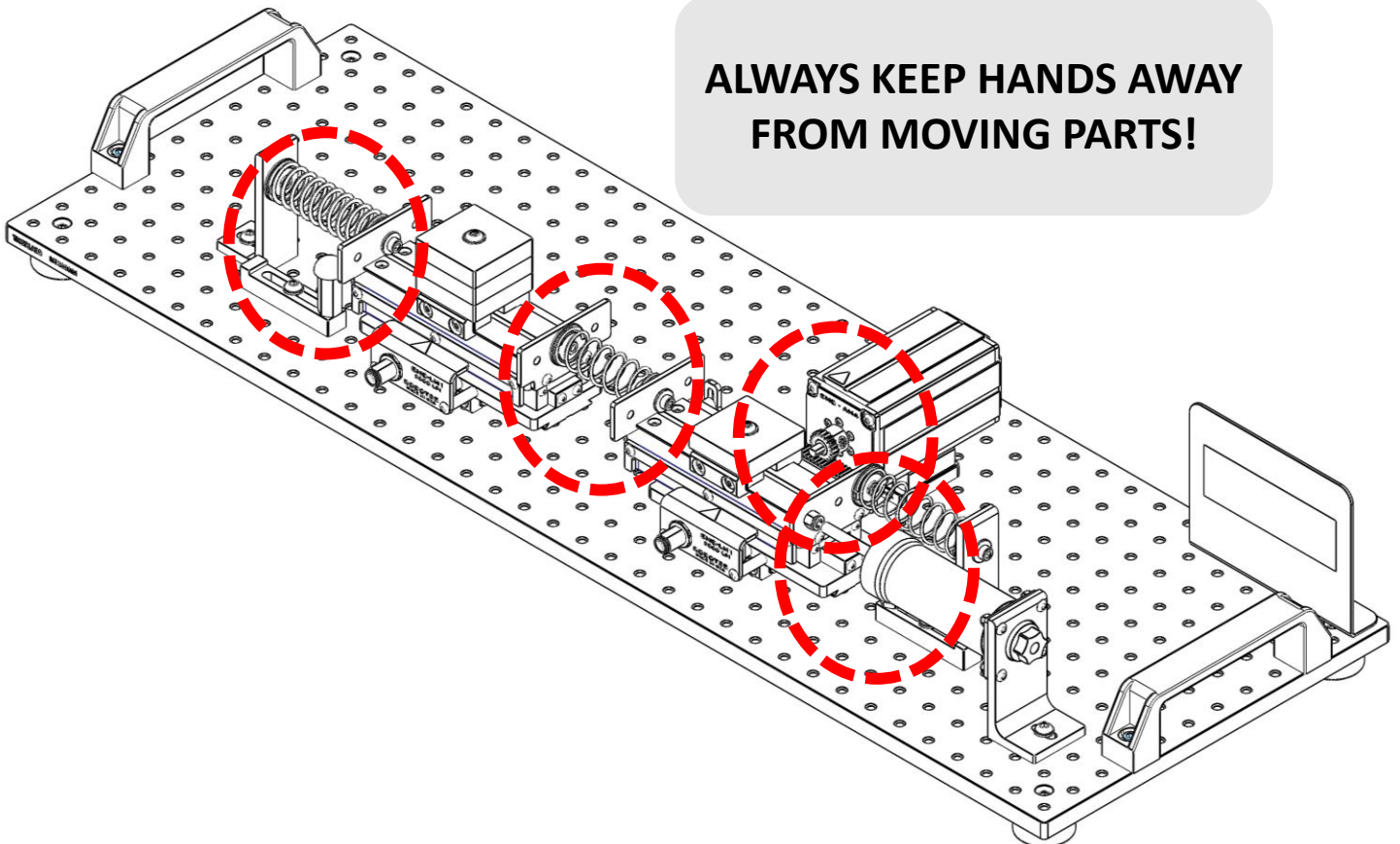

# Introduction

The EMB-IM1 is an interface module. This module is designed to interface with a DAQ, controller, or circuitry to monitor or control plants.

Examples of applications that the EMB-IM1 can be used for, are blinking LEDs, using a pushbutton as a dead man's switch, change direction or operating mode with the toggle switches.

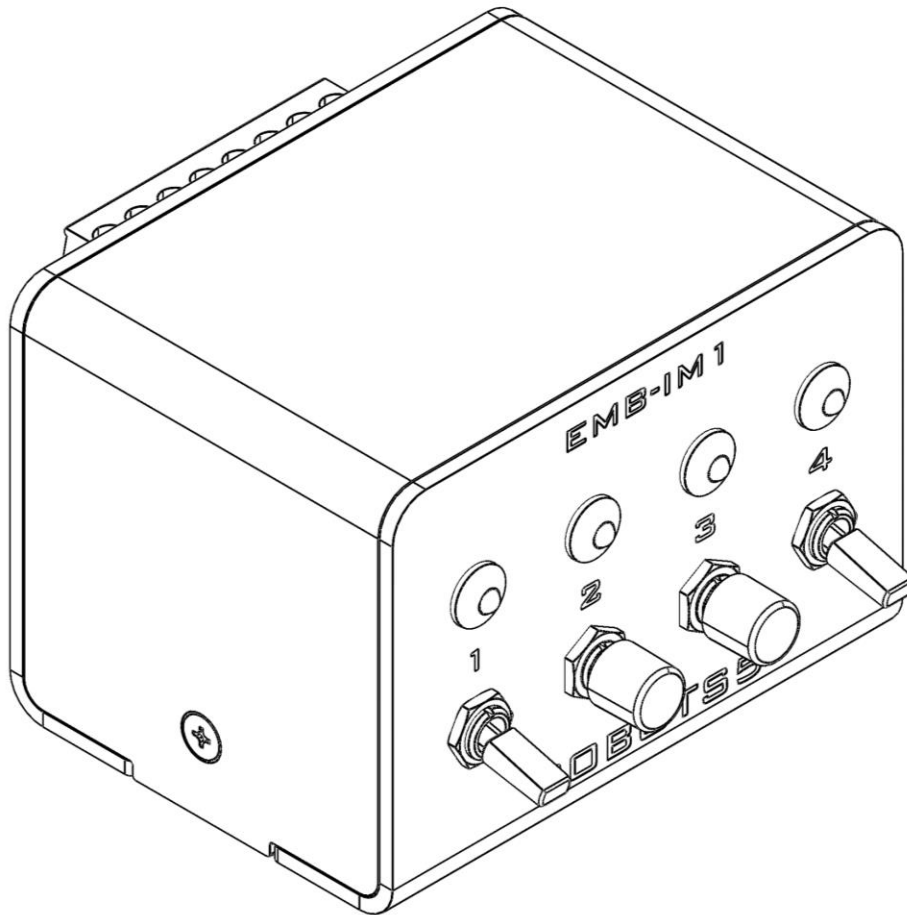

*Figure 1: EMB-IM1 Module*

The key features of the EMB-IM1 are presented bellow:

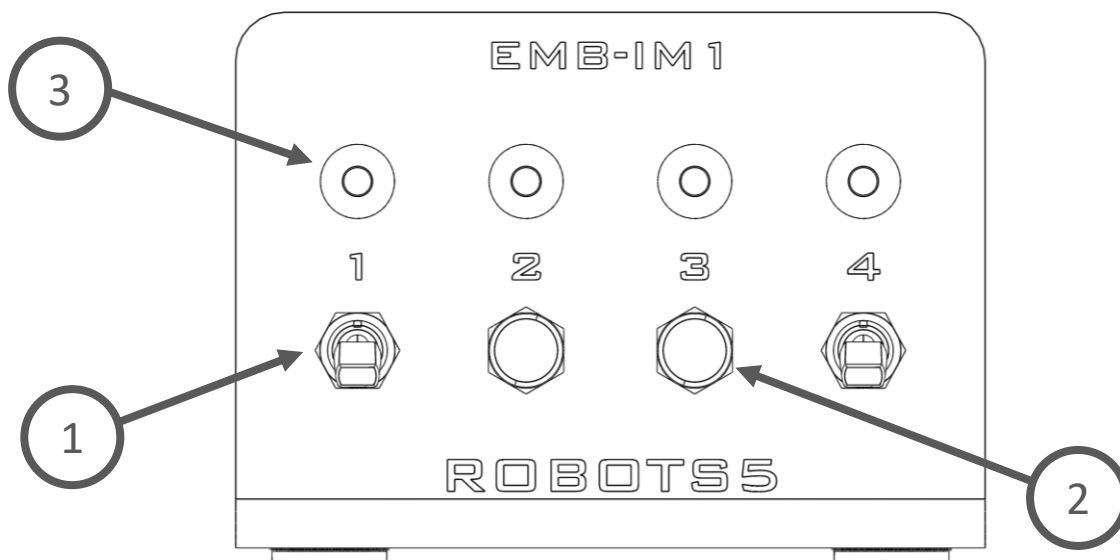

Figure 2: EMB-IM1, front view

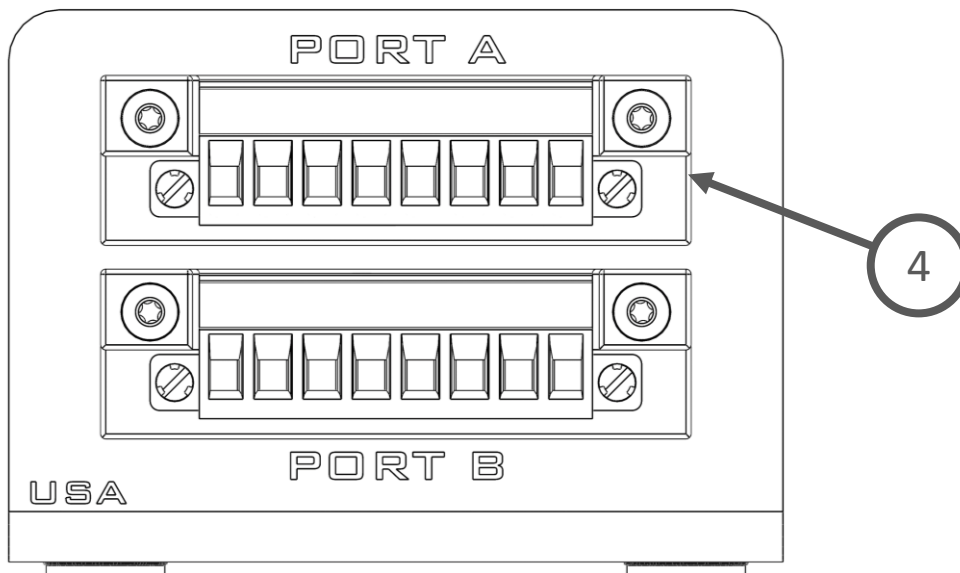

Figure 3: EMB-IM1, rear view

Item	Feature
1	Toggle Switch, quantity 2
2	Pushbutton, quantity 2
3	LED, quantity 4
4	Connector, quantity 2

Table 1: Key features of the EMB-IM1

# Specifications

The EMB-IM1 has 4 LEDs, 2 toggle switches, 2 pushbuttons, and 2 connectors.

Table 2 describes mechanical data related to the EMB-IM1:

Parameter	Value	Units
Pushbutton Operating Force	2.4	N
Toggle Switch Angle of Throw	25	°
LED Diameter	3.0	mm
LED Luminous Intensity	25	mcd
LED Wavelength	568	nm
LED Color	Green	-
IP Rating	IP40	-
Housing Material	Aluminum	-
Weight	0.18	kg

*Table 2: EMB-IM1, mechanical data*

Figure 4, shows the general dimensions of the module:

Units:  
mm, [in]

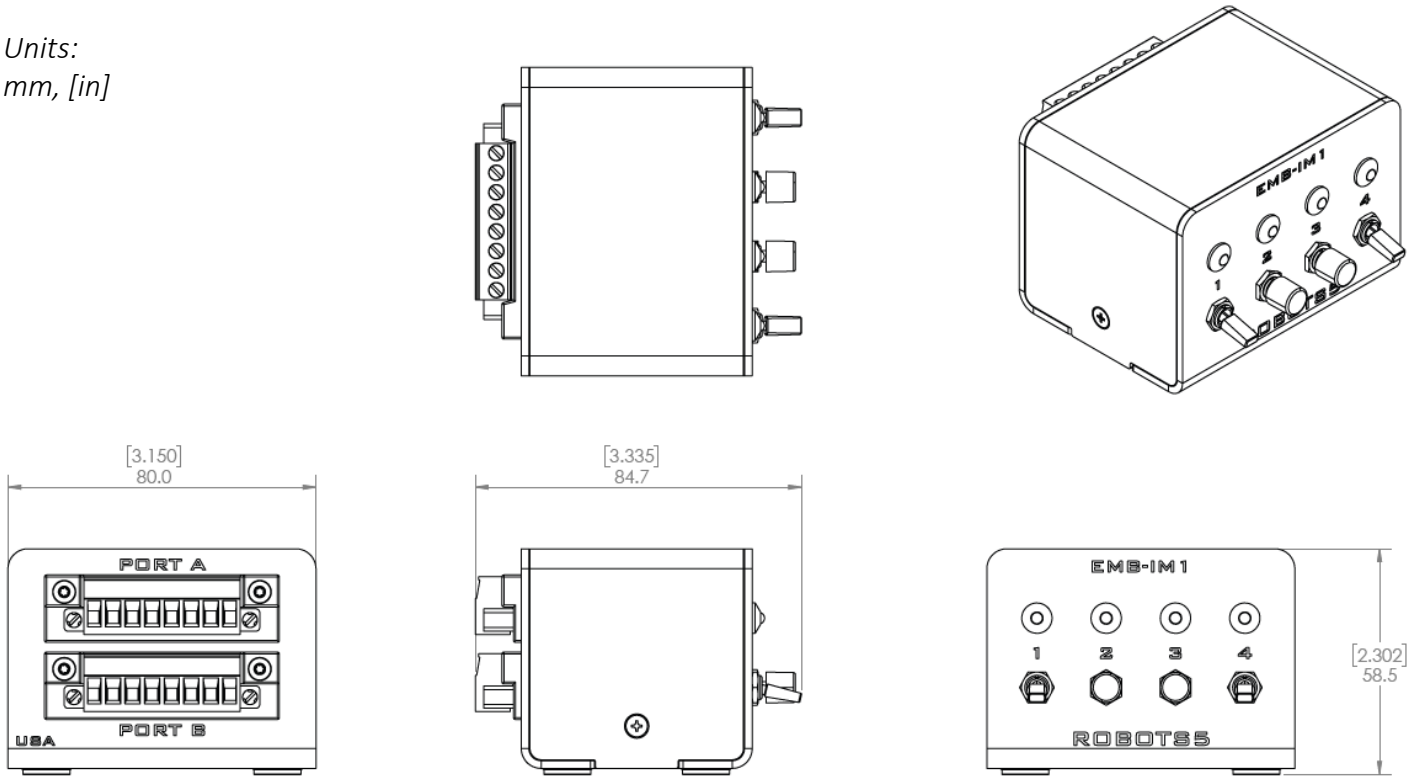

Figure 4: EMB-IM1, general dimensions

Table 3 describes the electrical specifications of the toggle switches:

Parameter	Value	Units
Current Rating Max.	1.0	A
Voltage Rating Max.	24.0	V

Table 3: Toggle switch electrical data



Table 4 describes the electrical specifications of the pushbuttons:

Parameter	Value	Units
Current Rating Max.	1.0	A
Voltage Rating Max.	24.0	V

*Table 4: Pushbutton electrical data*

Table 5 describes the electrical specifications of the LEDs:

Parameter	Value	Units
Inline Resistor Value	100	$\Omega$
LED Vf Typ.	2.1	V
LED Vf Max.	2.8	V
LED If Max.	30	mA
Reverse Voltage Max.	5	V
Reverse Current Max. (VR=5V)	100	$\mu$ A

*Table 5: LED electrical data*

We recommend powering the LEDs with 3.3V. Be very careful if operating at higher voltages as additional resistors might be needed.

The LED manufacturer is Bivar, and the P# is MPC3GDW12.0.

# Connections

Port A of the EMB-IM1 module is electrically connected to LEDs 1 and 2, toggle switch 1 and pushbutton 2.

Similarly, Port B of the EMB-IM1 module is electrically connected to LEDs 3 and 4, toggle switch 4, and pushbutton 3.

Figure 5 illustrates the relationship between Port A and Port B with the module components:

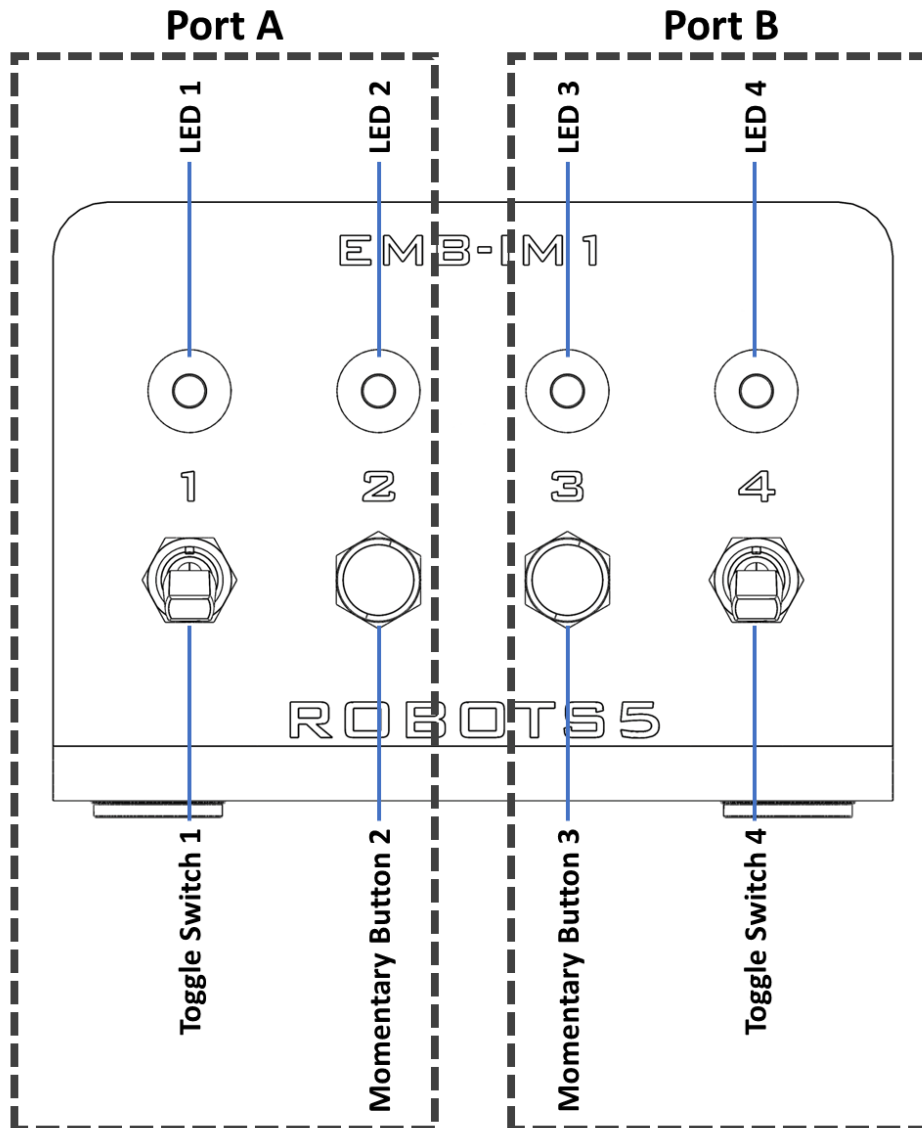
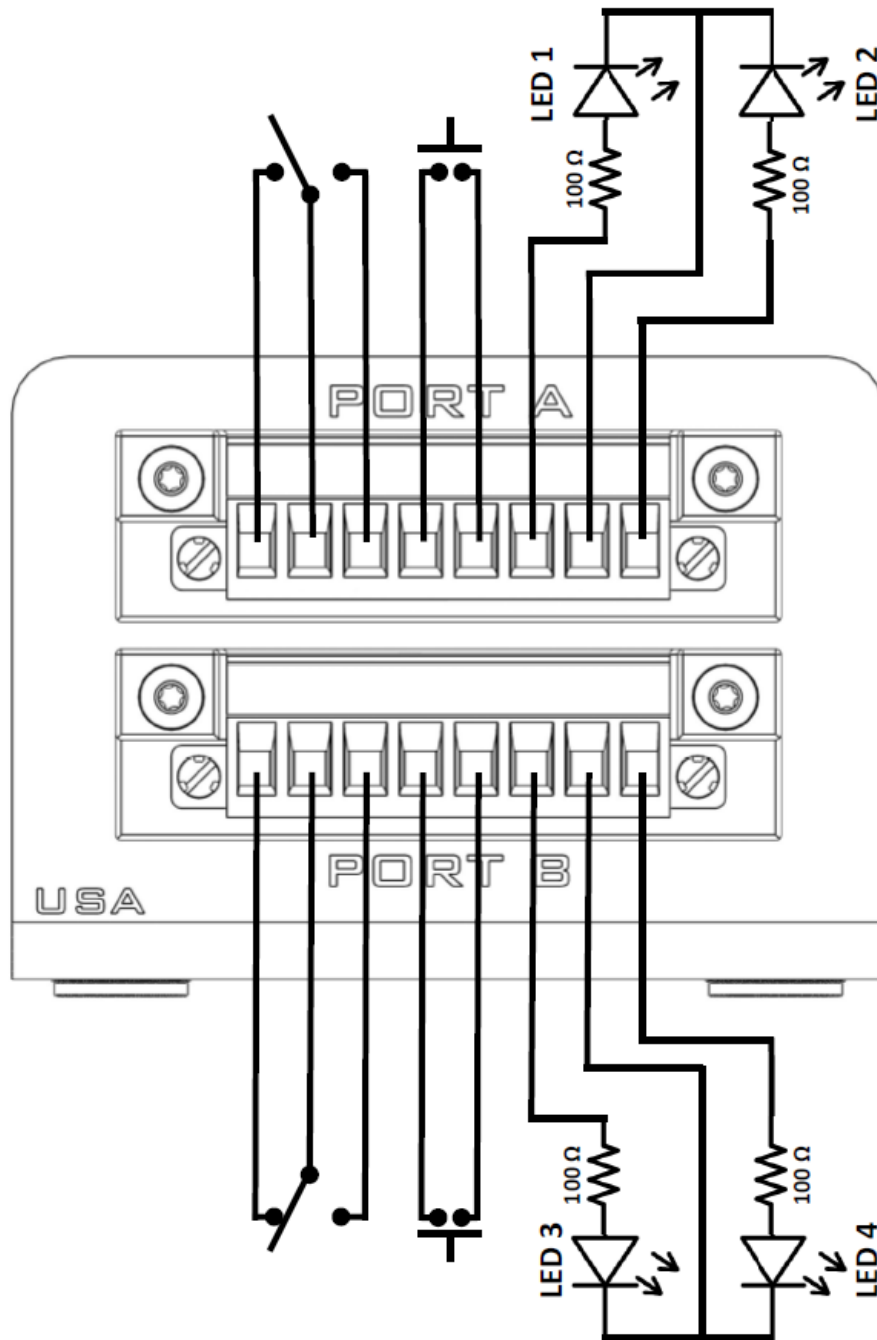

Figure 5: EMB-IM1, Port A and Port B division

Figure 6 illustrates the internal connections of each port and the pinout layout:



*Figure 6: EMB-IM1, schematics and pinout*

The connectors are a Phoenix Contact P# 0710235 (installed in the module).

Our standard mating connector offering is the Phoenix Contact P# 1778043, but there are additional mating connectors available such as the P# 1835151.

For the electrical connections, we recommend the use of ferrule or solder dip to the wire leads. We discourage the use of bare wires into the terminal connector.

Have questions or need additional support?

Contact us at:

Web: [www.robots5.com](http://www.robots5.com)

Email: [info@robots5.com](mailto:info@robots5.com)

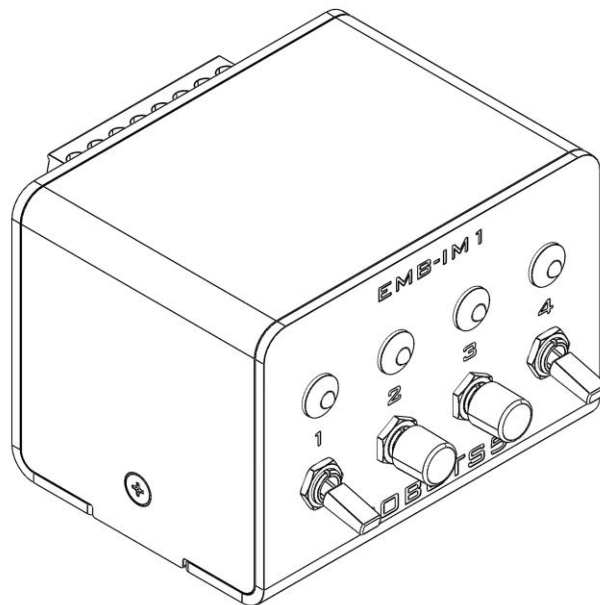

**ROBOTS5**