

ROBOTS5

ELECTRO-MECHANICAL BREADBOARD (EMB) MM2 USER MANUAL

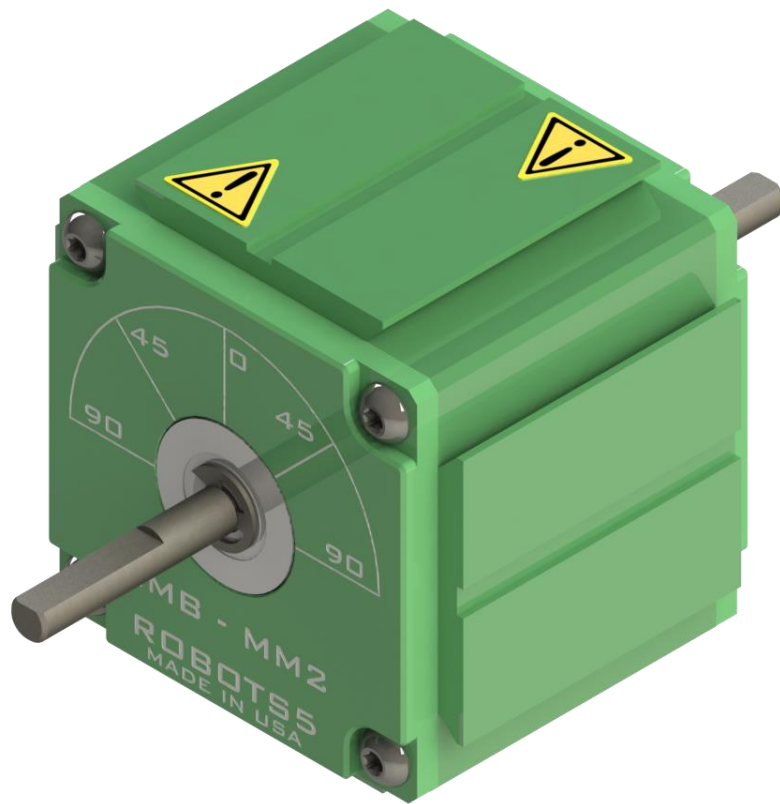

Version 2.20 - Jan.2025

ROBOTS5 LLC, USA



Disclaimer

- Be sure to read this document carefully and fully understand it, before using this product
- Be sure to read the “EMB Safety Document” carefully and fully understand it, before using this product
- Robots5 LLC is not responsible for any damage or injury caused by misuse, misunderstanding, or abuse of this product
- The user is solely responsible for the implementation of the controller and safety system used with our products
- This document was generated and completed to the best ability of Robots5 LLC. The information on this manual are presented in good faith and believed to be correct however, Robots5 LLC makes no warranties as to the completeness or accuracy of the information
- Never use our products in any application where failure of the product could result in personal injury. Failure to comply with these instructions could result in death or serious injury
- This equipment should not be used by inexperienced users, unless if they are under close supervision of experienced users. Safety operation must be ensured by experienced users
- Robots5 LLC reserves the right to make changes to this document or to the products described herein without further notice
- Make sure to always use the latest version of this document

Contact Information:

Email: info@robots5.com
Website: www.robots5.com
Location: Oviedo, FL USA

© 2025 Robots5 LLC., All Rights Reserved.



Safety

- If improperly used, EMB can cause injury or death
- Never touch any moving parts! Always stay clear from gears, sprockets, belts, chains, linkages, and any components in motion
- Follow all information and recommendations from this document and from the “EMB Safety Document”
- Do not disassemble or modify this device
- Responsible use of EMB is crucial to prevent dangerous conditions
- Make sure to disconnect power when handling this device
- Only use this device in indoor applications, with no water/oil splash or contact. Never operate EMB near explosive gases or flammable liquids
- Treat this device with care, it is a precision unit. Do not throw, hit, or drop it
- If you notice the unit getting warm or hot or making abnormal noises or vibrations, or sense smoke, immediately stop all motion and turn the power completely off. Assess the situation to completely understand the issue before attempting to resume operation
- Do not operate outside the specifications of the unit



Fingers may break or get amputated if caught in moving parts!

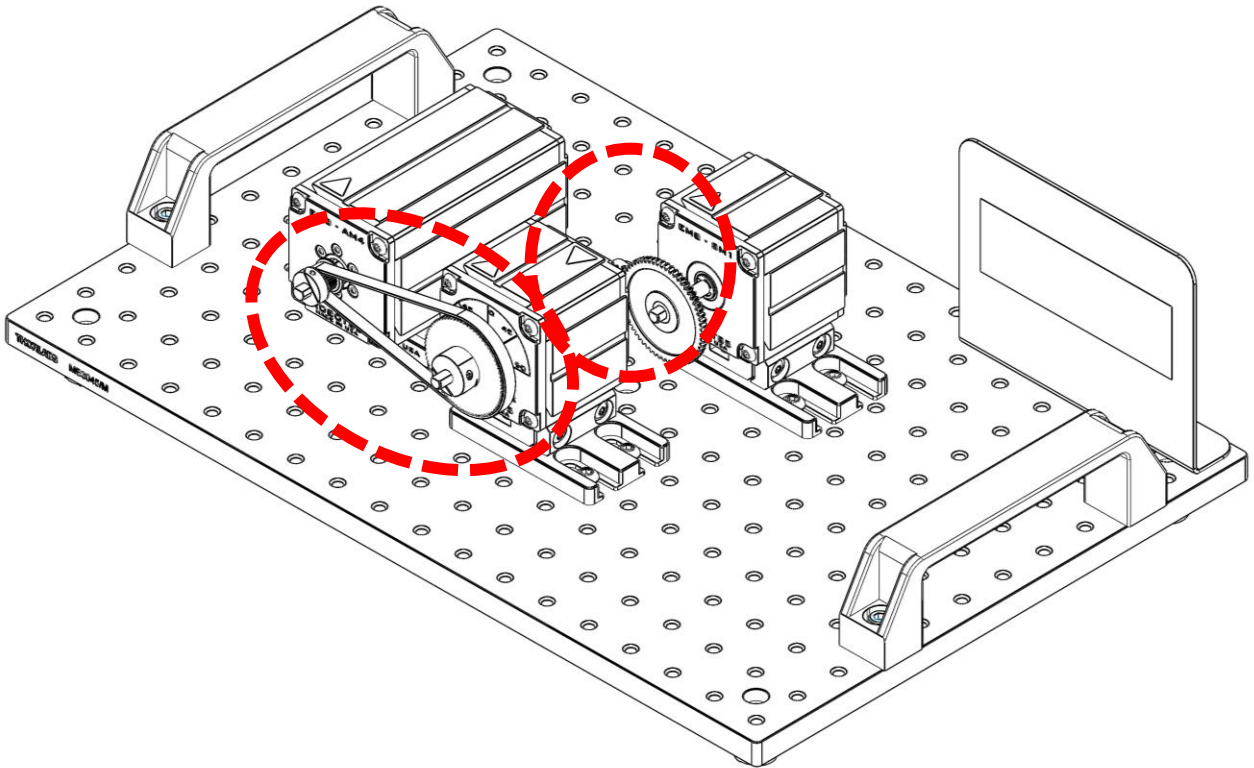

ALWAYS KEEP HANDS AWAY FROM MOVING PARTS!

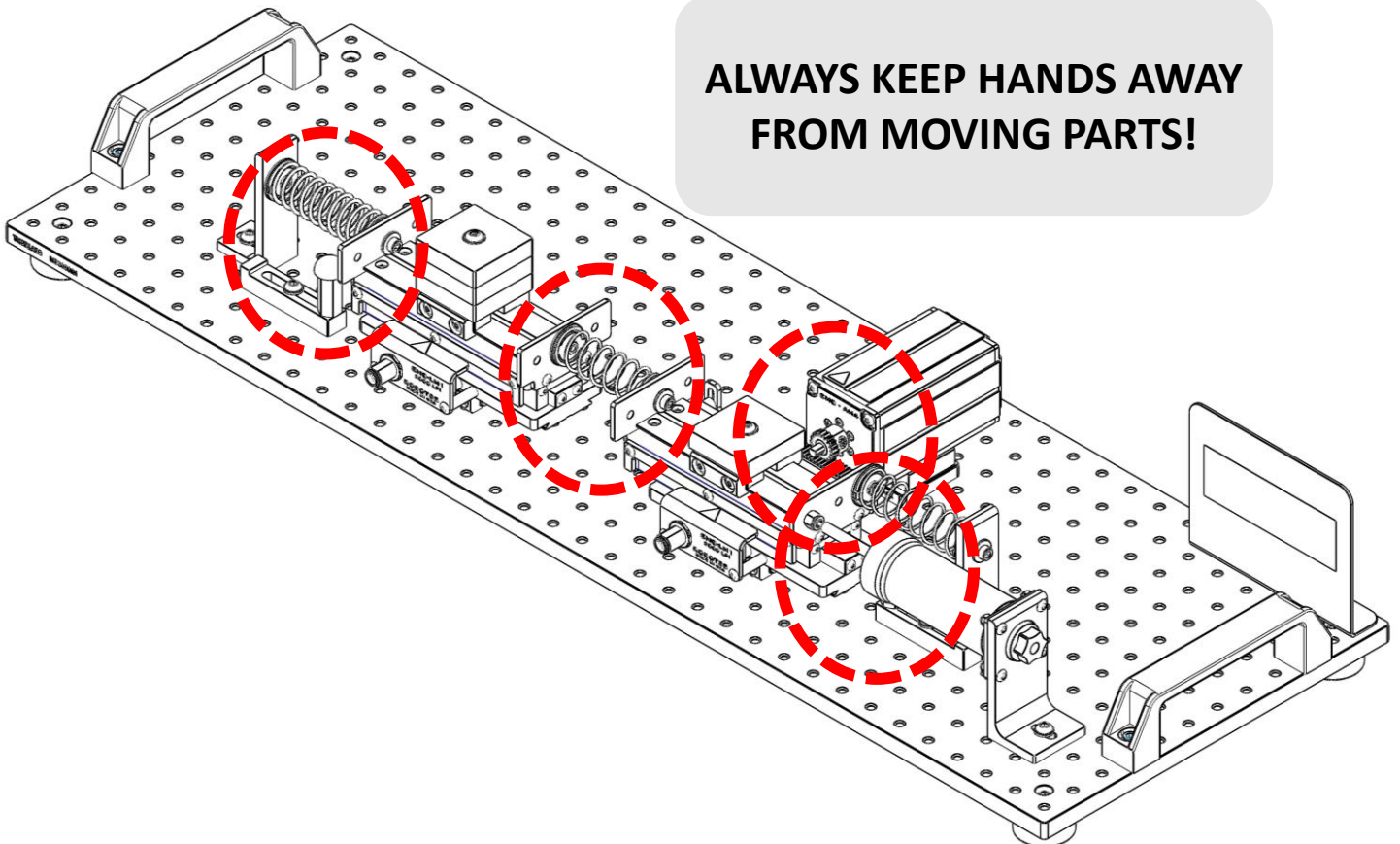

Introduction

The EMB-MM2 is a rotary bearing block module with a shaft that extends in both sides of the module.

This module is designed to interface with other EMB modules via components mounted to the drive shaft. Examples of components are gears, pulleys, sprockets, shaft couplers, and shaft collar hubs.

The green anodized aluminum body of the EMB-MM2 module relies on a dovetail approach for precision locating and firmly securing to a dovetail rail, breadboard, or other modules or accessories.

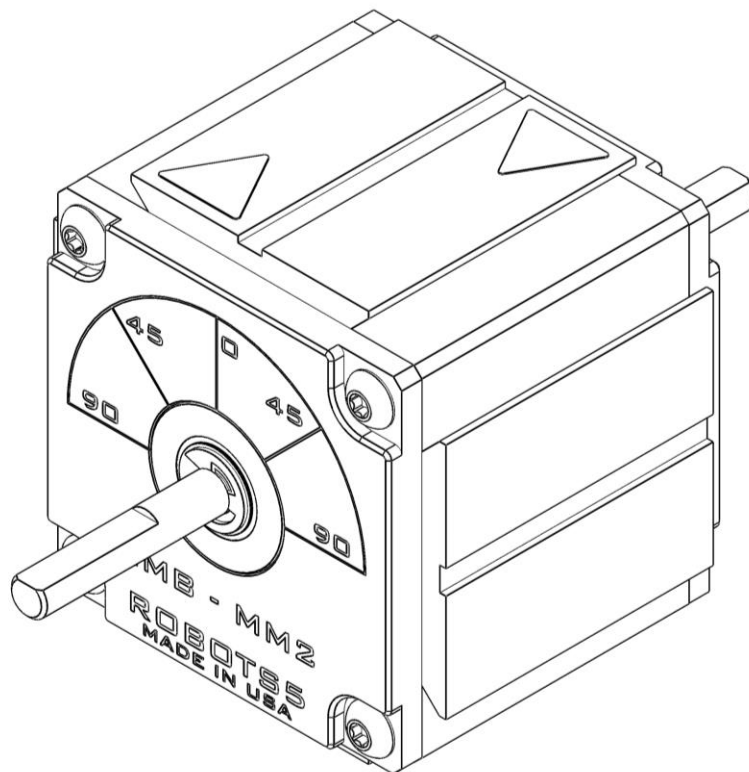

Figure 1: EMB-MM2 Module

The key features of the EMB-MM2 are presented bellow:

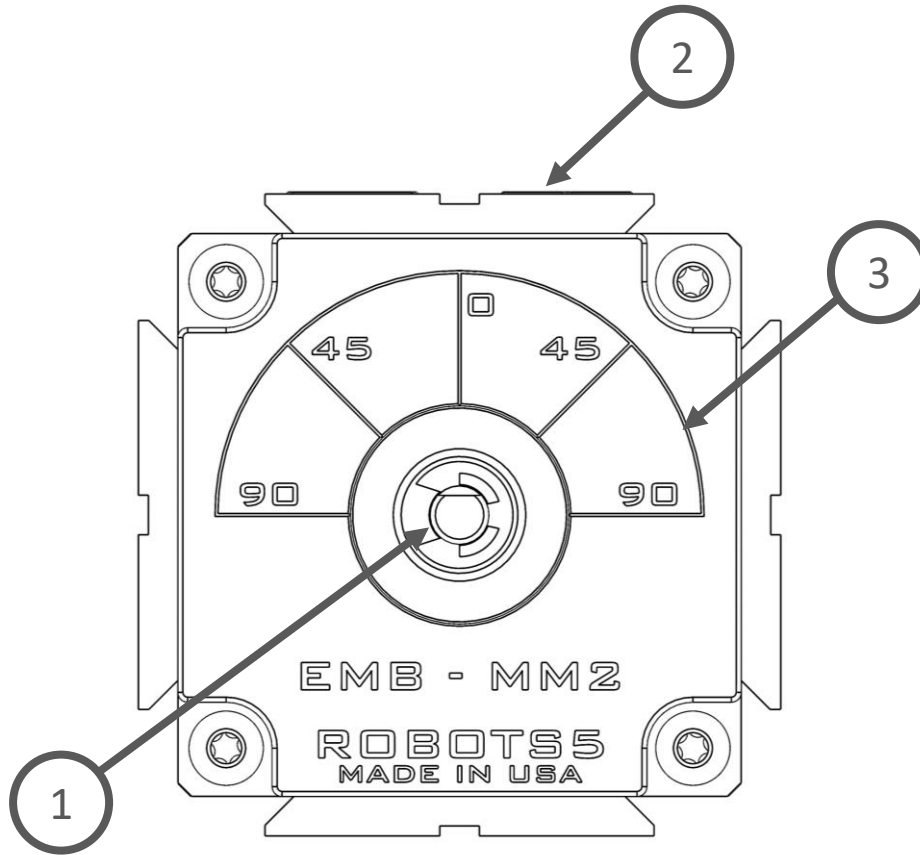

Figure 2: EMB-MM2

Item	Feature
1	Input Shaft, 2 sides
2	Dovetail Mount, 4 sides
3	Dial Marking, 2 sides

Table 1: Key features of the EMB-MM2

Specifications

The EMB-MM2 relies on a pair of precision bearings to provide a sturdy construction block for electro-mechanical plants.

Given the configuration of the EMB-MM2, it can provide higher axial and radial loading rating than sensor modules such as the EMB-SM1 and EMB-SM2. This makes the use of this module ideal for applications with higher loading requirements.

Table 2 describes the bearing block mechanical data.

Parameter	Value	Units
Max. Shaft Speed	5000	rpm
Mechanical Travel	Continuous	-
Max. Radial Load	30	N
Max. Axial Load	20	N
IP Rating	IP40	-
Housing Material	Aluminum	-
Shaft Material	Stainless Steel	-
Weight	0.32	kg

Table 2: Bearing block mechanical data

Figure 3, shows the general dimensions of the module:

Units:
mm, [in]

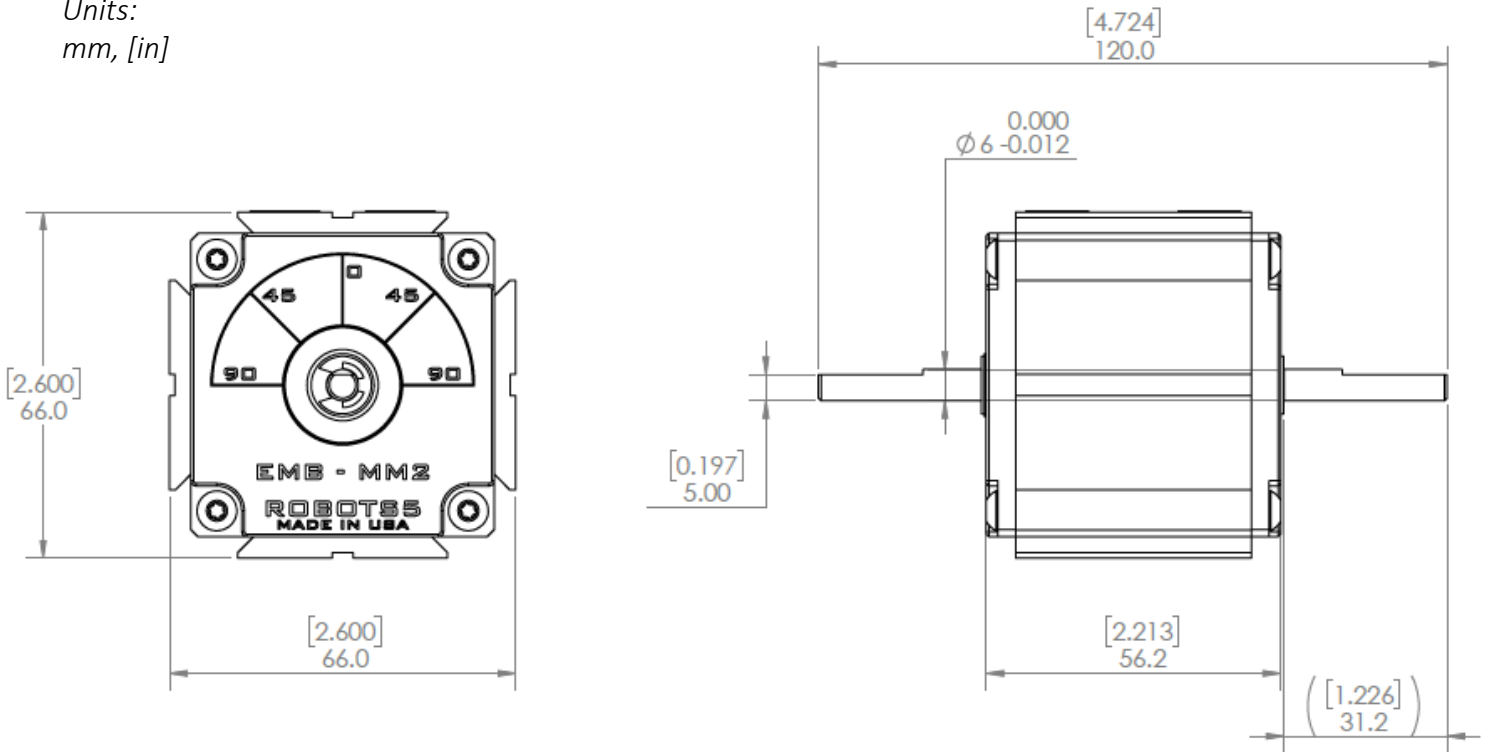

Figure 3: EMB-MM2, general dimensions

Note the shaft tolerance. Never press fit components to the shaft.

The laser marked dial, located on both sides of the module, can be used as a reference position.

The dovetail profile matches the XT66 66mm optical construction rails from Thorlabs.

There are several mounting options to interface with the dovetail, including XT66C4, XT66C2, and XT66P3 from Thorlabs.

Have questions or need additional support?

Contact us at:

Web: www.robots5.com

Email: info@robots5.com

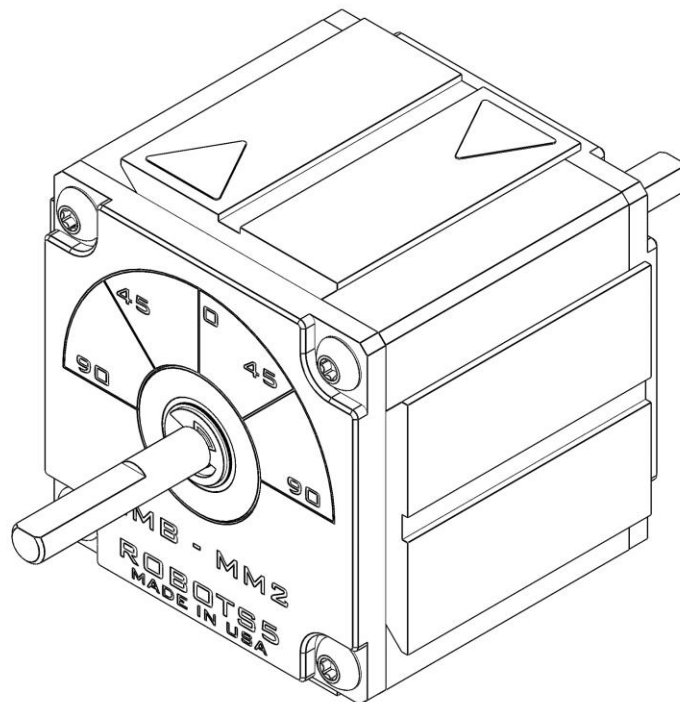

ROBOTS5