

ROBOTS5

ELECTRO-MECHANICAL BREADBOARD (EMB) SM2 USER MANUAL

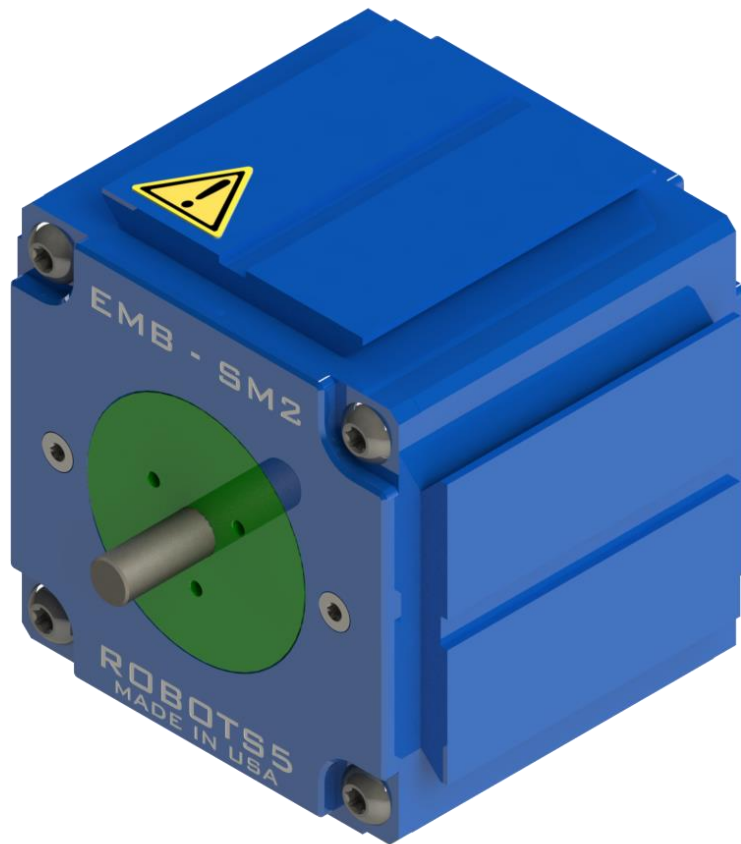

Version 2.20 - Jan.2025

ROBOTS5 LLC, USA



Disclaimer

- Be sure to read this document carefully and fully understand it, before using this product
- Be sure to read the “EMB Safety Document” carefully and fully understand it, before using this product
- Robots5 LLC is not responsible for any damage or injury caused by misuse, misunderstanding, or abuse of this product
- The user is solely responsible for the implementation of the controller and safety system used with our products
- This document was generated and completed to the best ability of Robots5 LLC. The information on this manual are presented in good faith and believed to be correct however, Robots5 LLC makes no warranties as to the completeness or accuracy of the information
- Never use our products in any application where failure of the product could result in personal injury. Failure to comply with these instructions could result in death or serious injury
- This equipment should not be used by inexperienced users, unless if they are under close supervision of experienced users. Safety operation must be ensured by experienced users
- Robots5 LLC reserves the right to make changes to this document or to the products described herein without further notice
- Make sure to always use the latest version of this document

Contact Information:

Email: info@robots5.com
Website: www.robots5.com
Location: Oviedo, FL USA

© 2025 Robots5 LLC., All Rights Reserved.



Safety

- If improperly used, EMB can cause injury or death
- Never touch any moving parts! Always stay clear from gears, sprockets, belts, chains, linkages, and any components in motion
- Follow all information and recommendations from this document and from the “EMB Safety Document”
- Do not disassemble or modify this device
- Responsible use of EMB is crucial to prevent dangerous conditions
- Make sure to disconnect power when handling this device
- Only use this device in indoor applications, with no water/oil splash or contact. Never operate EMB near explosive gases or flammable liquids
- Treat this device with care, it is a precision unit. Do not throw, hit, or drop it
- If you notice the unit getting warm or hot or making abnormal noises or vibrations, or sense smoke, immediately stop all motion and turn the power completely off. Assess the situation to completely understand the issue before attempting to resume operation
- Never hot-plug this module, turn off power before plugging it in or off
- Do not operate outside the specifications of the unit
- Don't plug the cable for the SM2 into the encoder port, damage will likely occur
- Powering this device outside the electrical rating will damage it



Fingers may break or get amputated if caught in moving parts!

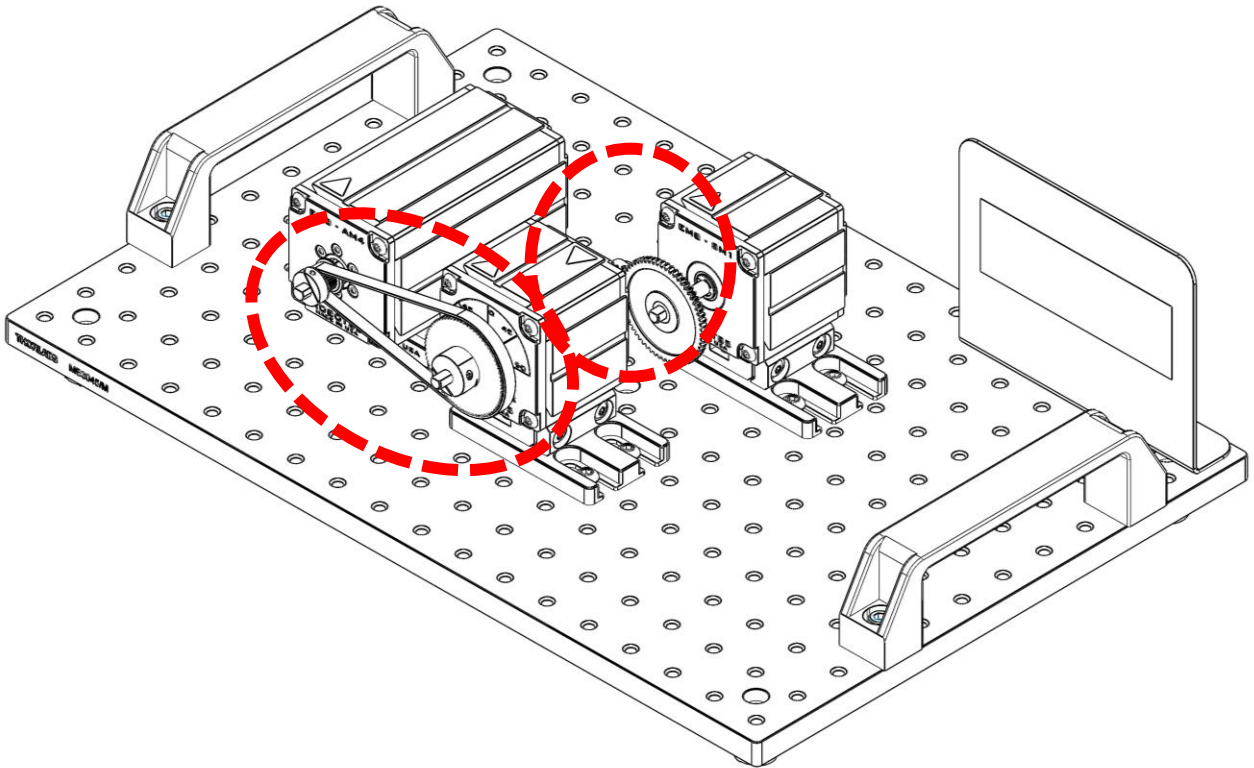

ALWAYS KEEP HANDS AWAY FROM MOVING PARTS!

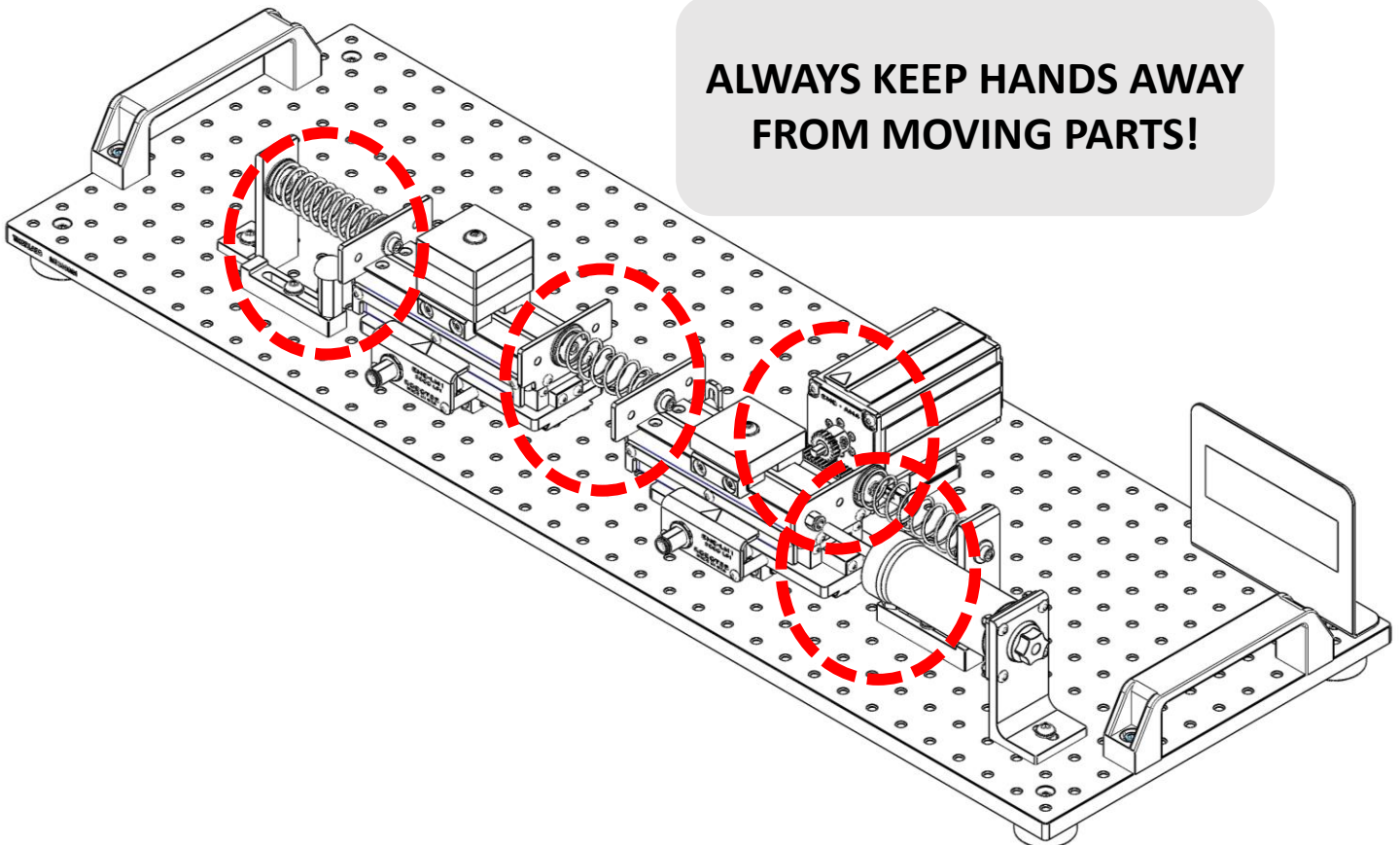

Introduction

The EMB-SM2 is a rotary potentiometer module. It is used to measure absolute angles.

This module is designed to interface with other EMB modules via components mounted to the drive shaft. Examples of components are gears, pulleys, sprockets, shaft couplers, and shaft collar hubs.

The blue anodized aluminum body of the EMB-SM2 module relies on a dovetail approach for precision locating and firmly securing to a dovetail rail, breadboard, or other modules or accessories.

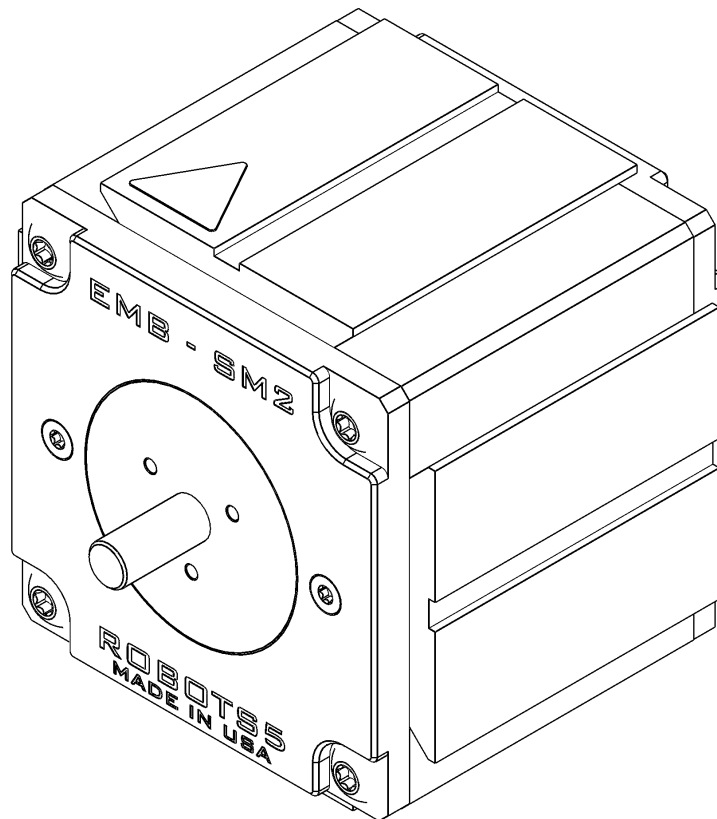

Figure 1: EMB-SM2 Module

The key features of the EMB-SM2 are presented bellow:

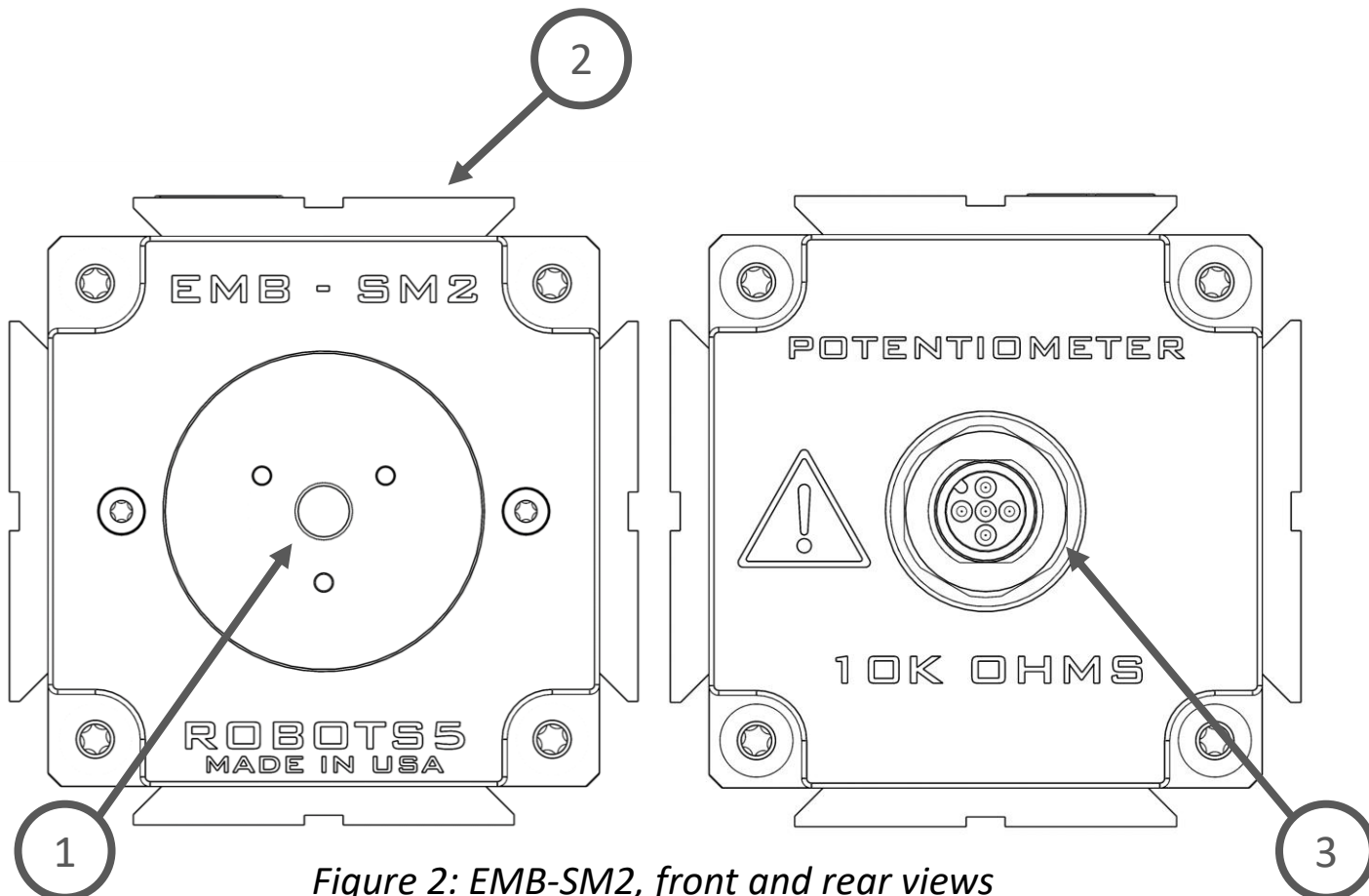

Figure 2: EMB-SM2, front and rear views

Item	Feature
1	Input Shaft
2	Dovetail Mount, 4 sides
3	M12, 5 Pole Connector

Table 1: Key features of the EMB-SM2

Specifications

The EMB-SM2 relies on a precision potentiometer to measure the angular position of the shaft. It performs an absolute angle measurement, not a relative measurement like an incremental encoder (EMB-SM1).

There are no mechanical hard-stops, therefore the shaft can rotate continuously. The electrical range of motion is 340°, at the end of the electrical travel, there is a roll-over condition (both directions of motion).

Table 2 describes the potentiometer mechanical data.

Parameter	Value	Units
Max. Shaft Speed	500	rpm
Mechanical Travel	Continuous	-
Life Cycles	10 Million	-
Max. Radial Load	5	N
Max. Axial Load	3	N
IP Rating	IP40	-
Housing Material	Aluminum	-
Shaft Material	Stainless Steel	-
Weight	0.35	kg

Table 2: Potentiometer mechanical data

Figure 3, shows the general dimensions of the module:

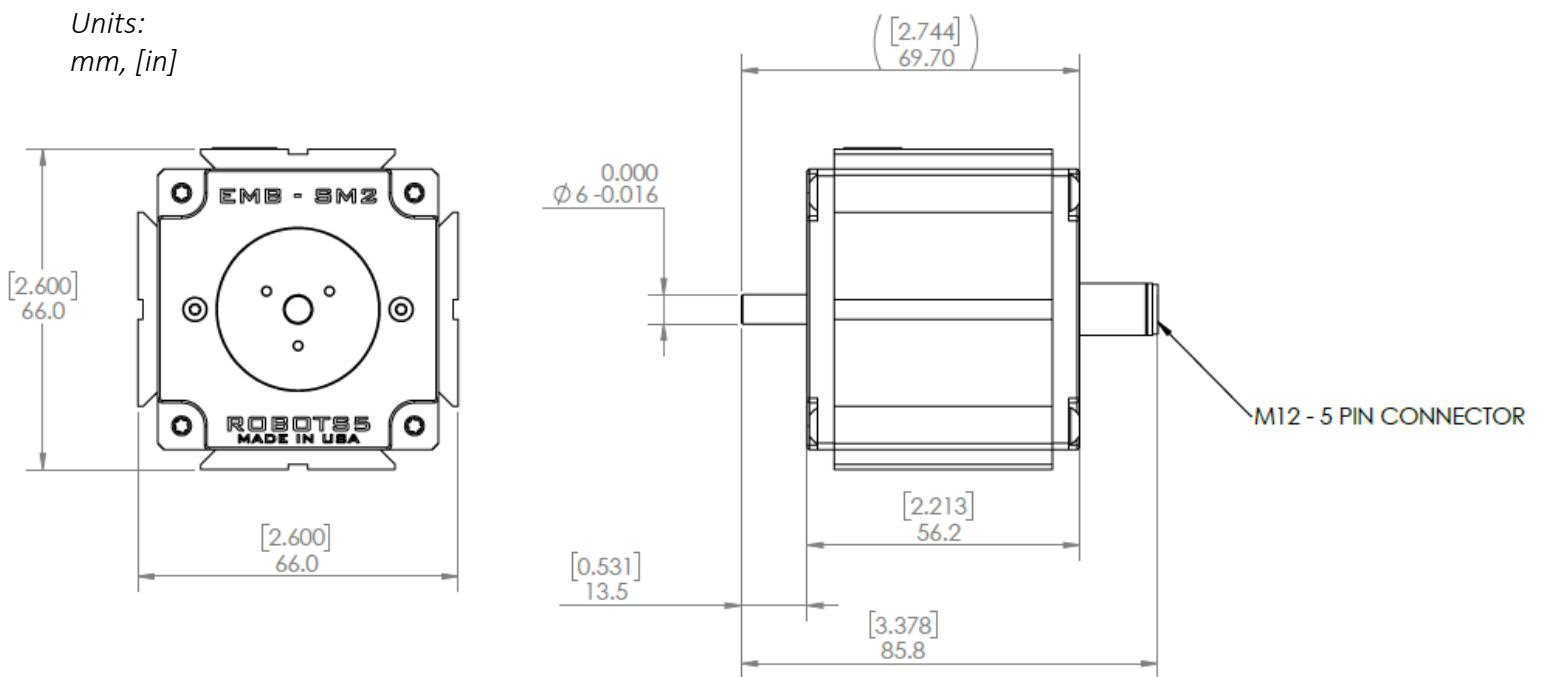

Figure 3: EMB-SM2, general dimensions

Note the shaft tolerance. Never press fit components to the shaft.

The dovetail profile matches the XT66 66mm optical construction rails from Thorlabs.

There are several mounting options to interface with the dovetail, including XT66C4, XT66C2, and XT66P3 from Thorlabs.

Due to the conductive plastic sliding surface of the potentiometer internals, the sensor produces a sliding sound when in motion. This is normal.

The standard resistance value for the EMB-SM2 is 10k Ω .

We can also supply the EMB-SM2 module with different resistance values, if your application requires (0.5k Ω , 1k Ω , 2k Ω , or 5k Ω).

This potentiometer outputs an analog voltage proportional to the shaft angle.

Slight continuous vibration such as dither will decrease the lifetime of the sensor.

Table 3 describes the electrical specifications:

Parameter	Value	Units
Effective Electrical Travel	340 (+2, -3)	°
Total Resistance	10k	Ω
Total Resistance Tolerance	±20	%
Independent Linearity	±1	%
Max. Rated Dissipation	2	W
TC of Resistance	±400	ppm/K
Weight	0.35	kg

Table 3: Potentiometer electrical data

Bellow is the schematic representation of the sensor, the numbers match the module pin out:

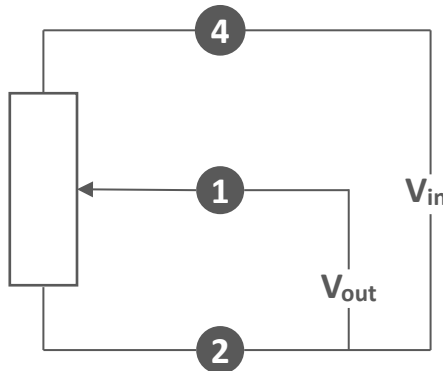

Figure 4: EMB-SM2 Schematic

To avoid burnout of the resistive element, do not supply more than 1mA to terminal 1 (output).

To reduce sliding noise, add load resistance. This should be more than 100 times and less than 1000 times of total resistance.

Connections

Figure 5 and Table 4, show the pin out of the connector:

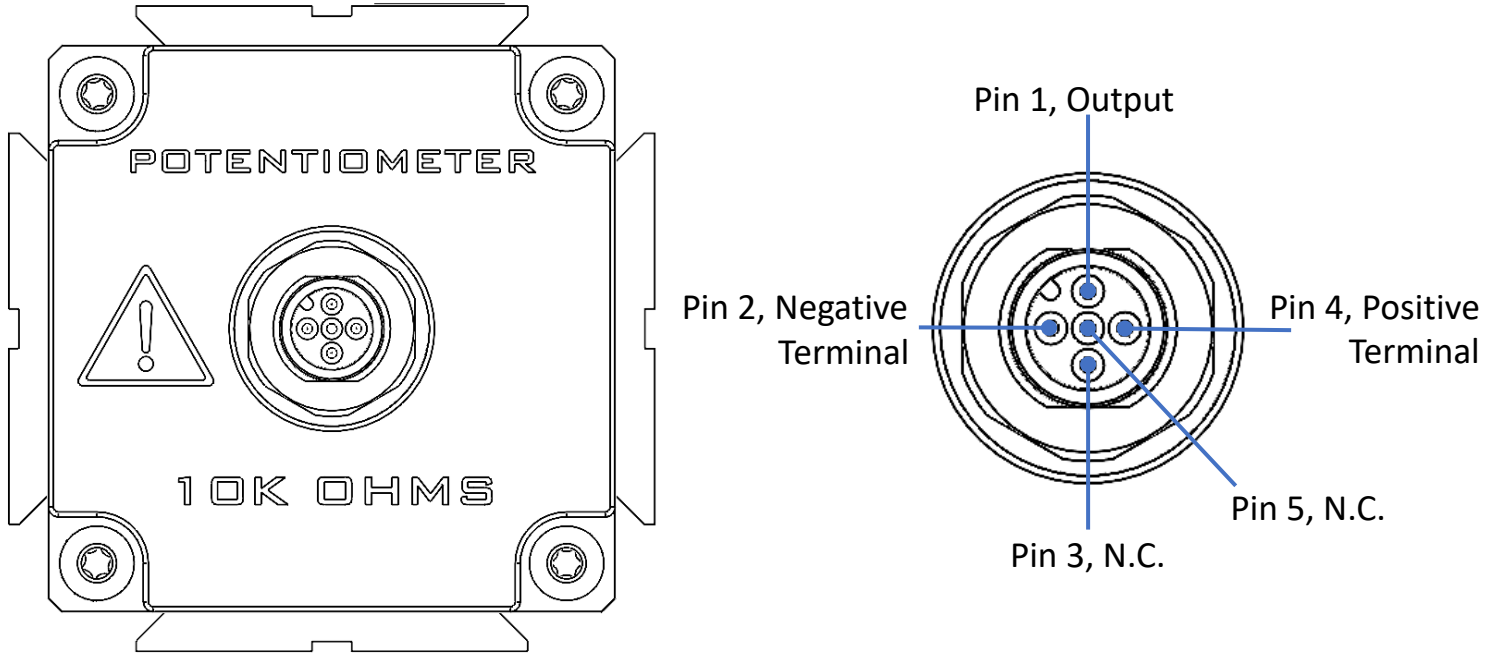

Figure 5: EMB-SM2, pin out

Pin	Signal	Wire Color ¹
1	Output	Brown
2	Negative Terminal	White
3	N.C.	Blue
4	Positive Terminal	Black
5	N.C.	Gray ²

Table 4: Potentiometer pin out

¹ = for Murrelektronik cables
² = or green

Connection to the EMB-SM2 is made through the Murrelektronik M12-5 pole connector. This is a standard industrial connector type.

There are several options for cables, including:

Murrelektronik PN	Feature
7000-40041-0250100	M12 axial Male to M12 axial Female, 5-pole, length 1m
7000-40041-0250300	M12 axial Male to M12 axial Female, 5-pole, length 3m
7000-12241-0250300	M12 axial female to pigtail, 5-pole, length 3m
7000-12361-0250300	M12 right-angle female to pigtail, 5-pole, length 3m
4-Pole Cables	
7000-40021-0240100	M12 axial Male to M12 axial Female, 4-pole, length 1m
7000-40021-0240300	M12 axial Male to M12 axial Female, 4-pole, length 3m
7000-12221-0240200	M12 axial female to pigtail, 4-pole, length 2m
7000-12341-0240200	M12 right-angle female to pigtail, 4-pole, length 2m

Table 5: Cable options

Note, the potentiometer module only uses 3 out of the 5 pins, therefore, when interfacing with the EMB-SM2, you can use a 5-pole or a 4-pole cable.

The maximum cable length allowed, to keep a good signal integrity is 3m. We recommend using a shorter cable if your application allows.

If you are using a pigtail option cable, making an incorrect connection or shorting the leads will likely permanently damage the module.

Have questions or need additional support?

Contact us at:

Web: www.robots5.com

Email: info@robots5.com

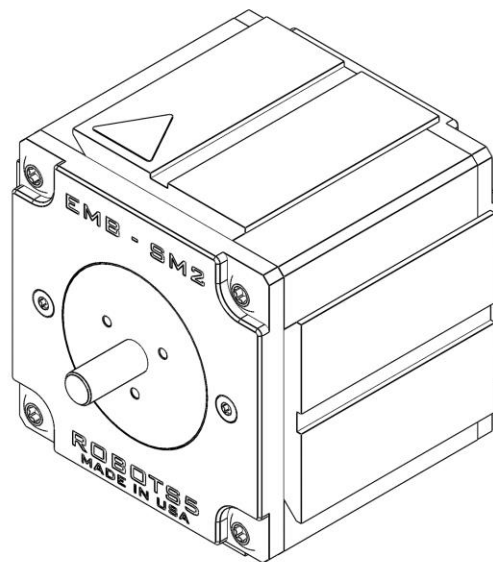

ROBOTS5