

ROBOTS5

ELECTRO-MECHANICAL BREADBOARD (EMB) SM1 USER MANUAL

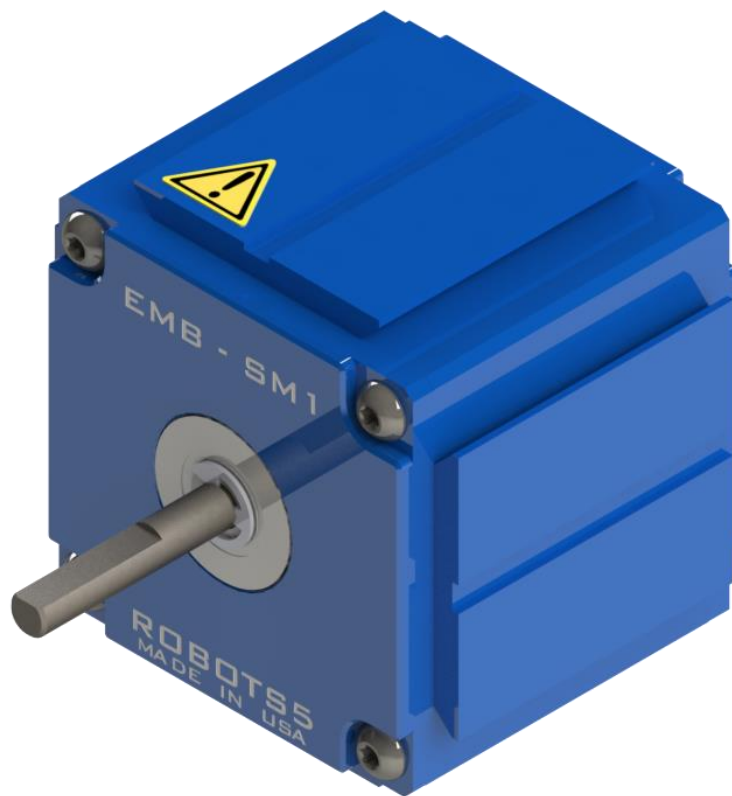

Version 2.10 - Apr. 2024

ROBOTS5 LLC, USA



Disclaimer

- Be sure to read this document carefully and fully understand it, before using this product
- Be sure to read the “EMB Safety Document” carefully and fully understand it, before using this product
- Robots5 LLC is not responsible for any damage or injury caused by misuse, misunderstanding, or abuse of this product
- The user is solely responsible for the implementation of the controller and safety system used with our products
- This document was generated and completed to the best ability of Robots5 LLC. The information on this manual are presented in good faith and believed to be correct however, Robots5 LLC makes no warranties as to the completeness or accuracy of the information
- Never use our products in any application where failure of the product could result in personal injury. Failure to comply with these instructions could result in death or serious injury
- This equipment should not be used by inexperienced users, unless if they are under close supervision of experienced users. Safety operation must be ensured by experienced users
- Robots5 LLC reserves the right to make changes to this document or to the products described herein without further notice
- Make sure to always use the latest version of this document

Contact Information:

Email: info@robots5.com

Website: www.robots5.com

Location: Melbourne, FL USA

© 2024 Robots5 LLC., All Rights Reserved.



Safety

- If improperly used, EMB can cause injury or death
- Never touch any moving parts! Always stay clear from gears, sprockets, belts, chains, linkages, and any components in motion
- Never place fingers or hands between moving components and hard stops
- Follow all information and recommendations from this document and from the “EMB Safety Document”
- Do not disassemble or modify this device
- Responsible use of EMB is crucial to prevent dangerous conditions
- Make sure to disconnect power when handling this device
- Only use this device in indoor applications, with no water/oil splash or contact. Never operate EMB near explosive gases or flammable liquids
- Treat this device with care, it is a precision unit. Do not throw, hit, or drop it
- If you notice the unit getting warm or hot or making abnormal noises or vibrations, or sense smoke, immediately stop all motion and turn the power completely off. Assess the situation to completely understand the issue before attempting to resume operation
- Never hot-plug this module, turn off power before plugging it in or off
- Do not operate outside the specifications of the unit
- Do not plug the cable for the SM1 into the potentiometer port , damage will likely occur
- Powering this device outside the electrical rating will damage it



Fingers may break or get amputated if caught in moving parts!

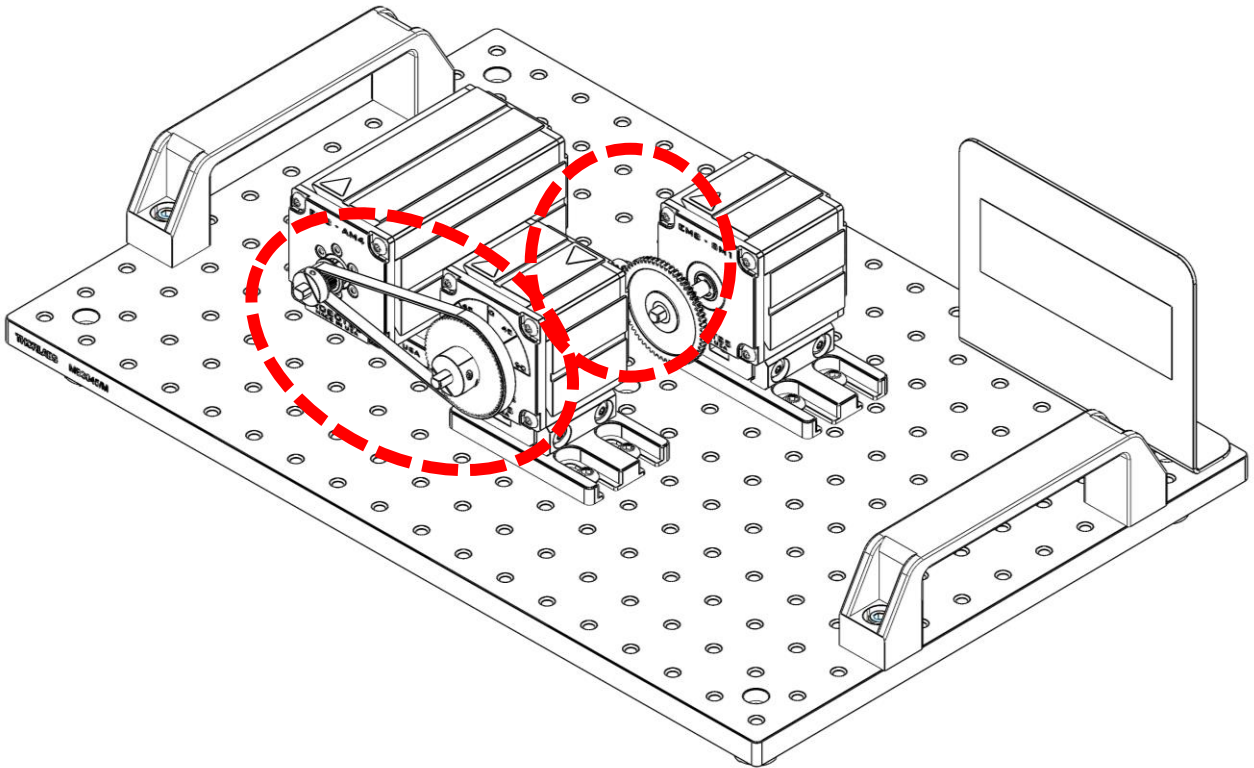

ALWAYS KEEP HANDS AWAY FROM MOVING PARTS!

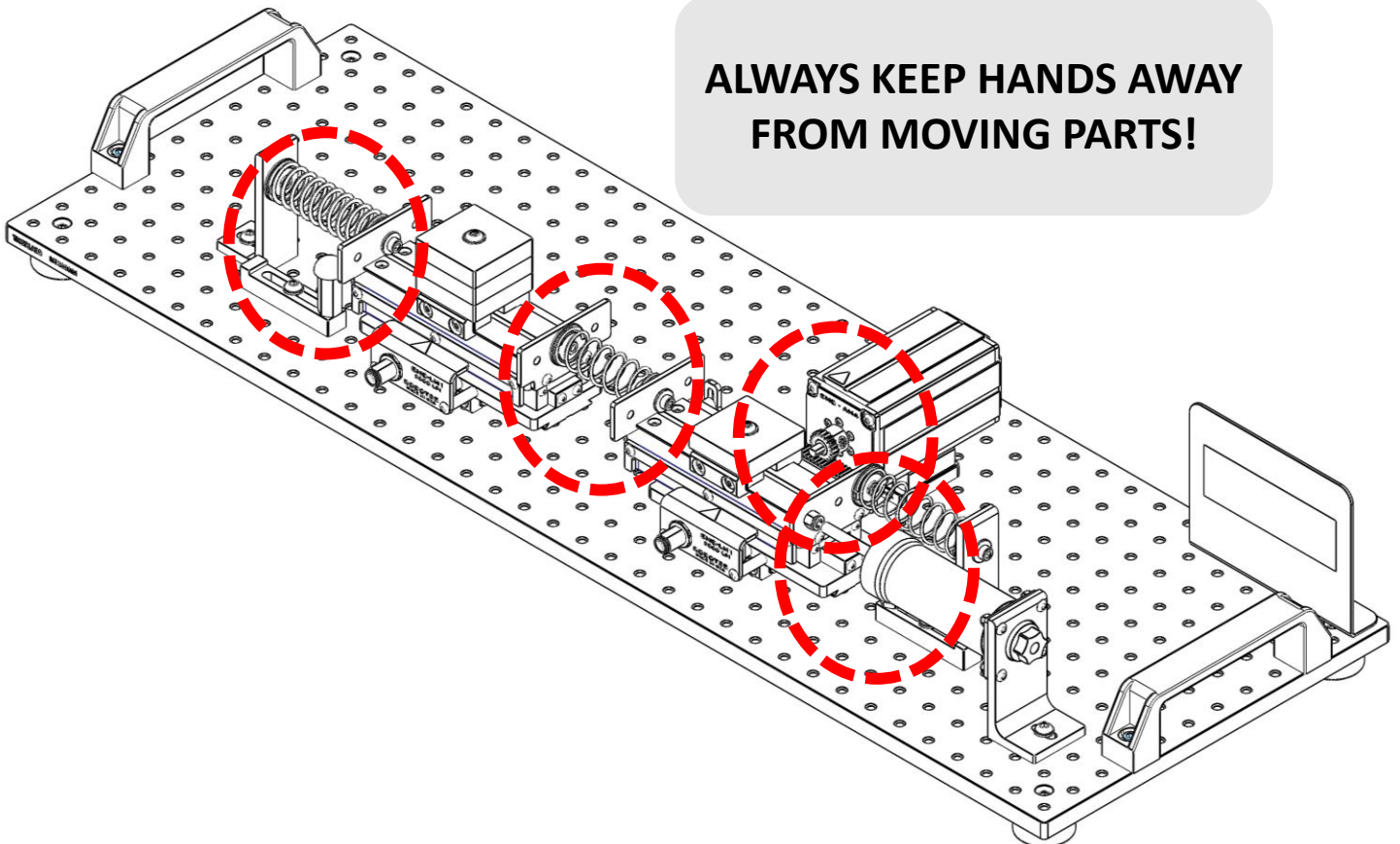

Introduction

The EMB-SM1 is a rotary incremental encoder module. It is used to measure relative angles.

This module is designed to interface with other EMB modules via components mounted to the drive shaft. Examples of components are gears, pulleys, sprockets, shaft couplers, and shaft collar hubs.

The blue anodized aluminum body of the EMB-SM1 module relies on a dovetail approach for precision locating and firmly securing to a dovetail rail, breadboard, or other modules or accessories.

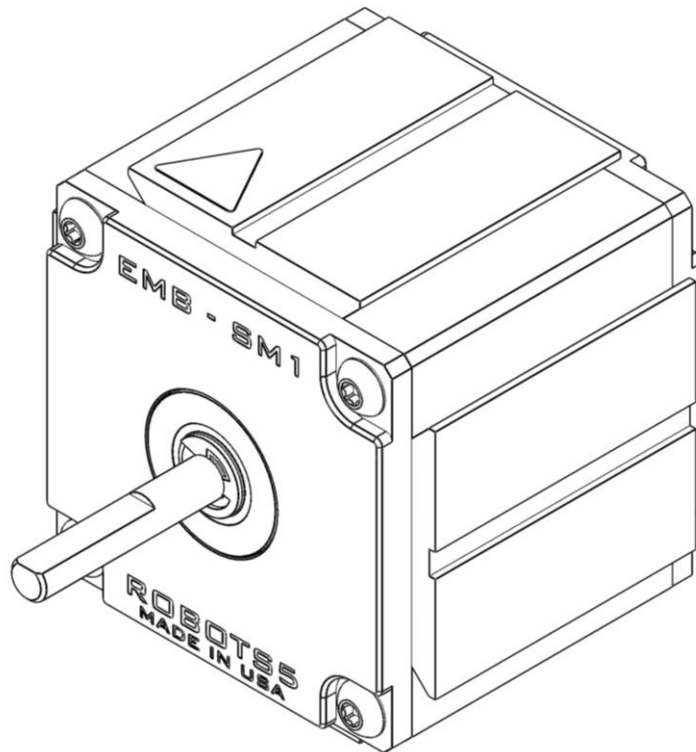

Figure 1: EMB-SM1 Module

The key features of the EMB-SM1 are presented bellow:

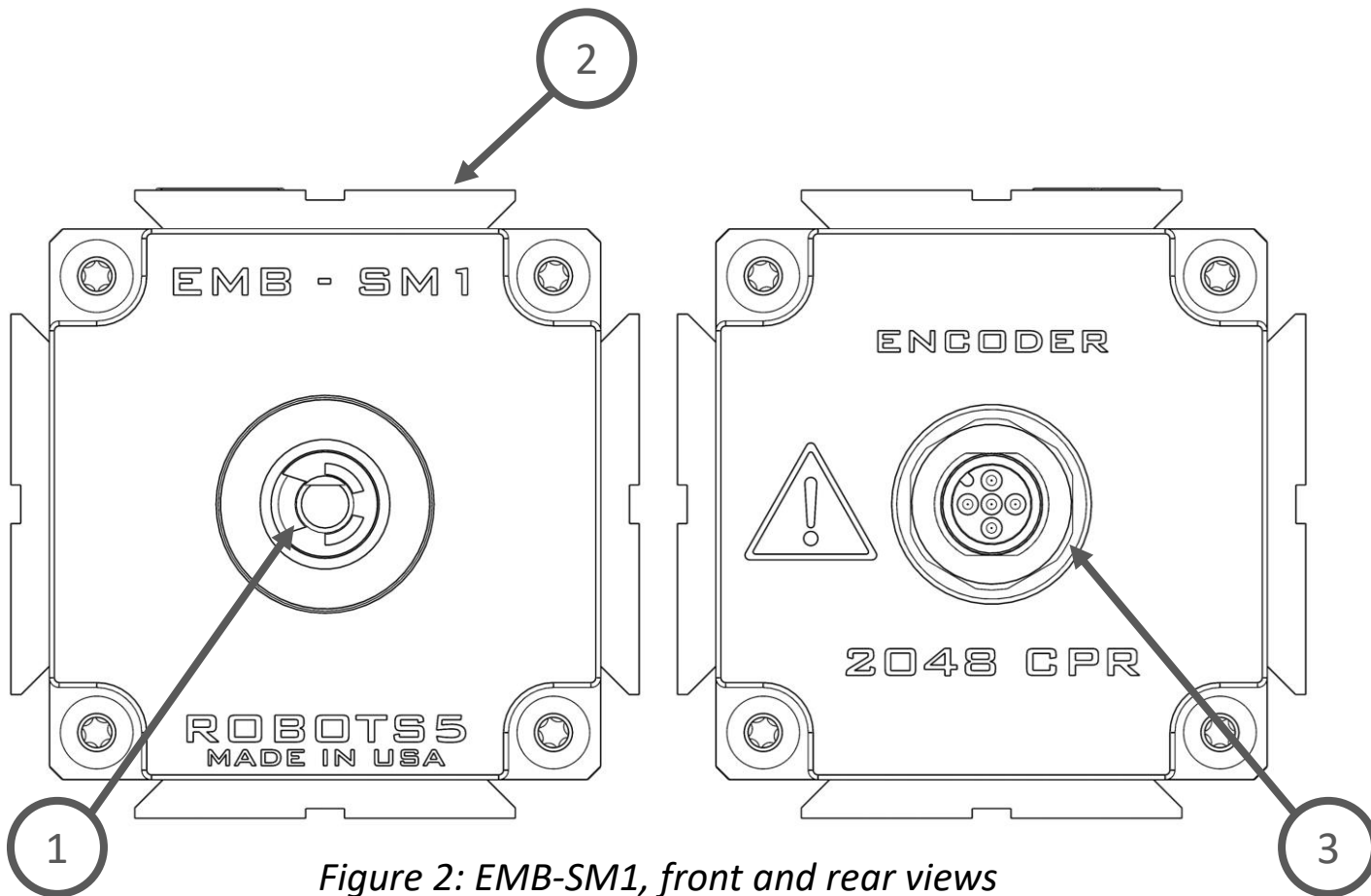

Figure 2: EMB-SM1, front and rear views

| Item | Feature |
|------|-------------------------|
| 1 | Input Shaft |
| 2 | Dovetail Mount, 4 sides |
| 3 | M12, 5 Pole Connector |

Table 1: Key features of the EMB-SM1

Specifications

The EMB-SM1 relies on a single-ended optical incremental. It performs a relative angle measurement, not an absolute measurement like a potentiometer (EMB-SM2).

Table 2 describes the encoder mechanical data.

| Parameter | Value | Units |
|-------------------|-----------------|--------------|
| Max. Shaft Speed | 5000 | rpm |
| Mechanical Travel | Continuous | - |
| Max. Radial Load | 20 | N |
| Max. Axial Load | 10 | N |
| IP Rating | IP40 | - |
| Housing Material | Aluminum | - |
| Shaft Material | Stainless Steel | - |
| Weight | 0.41 | kg |

Table 2: Encoder mechanical data

Figure 3, shows the general dimensions of the module:

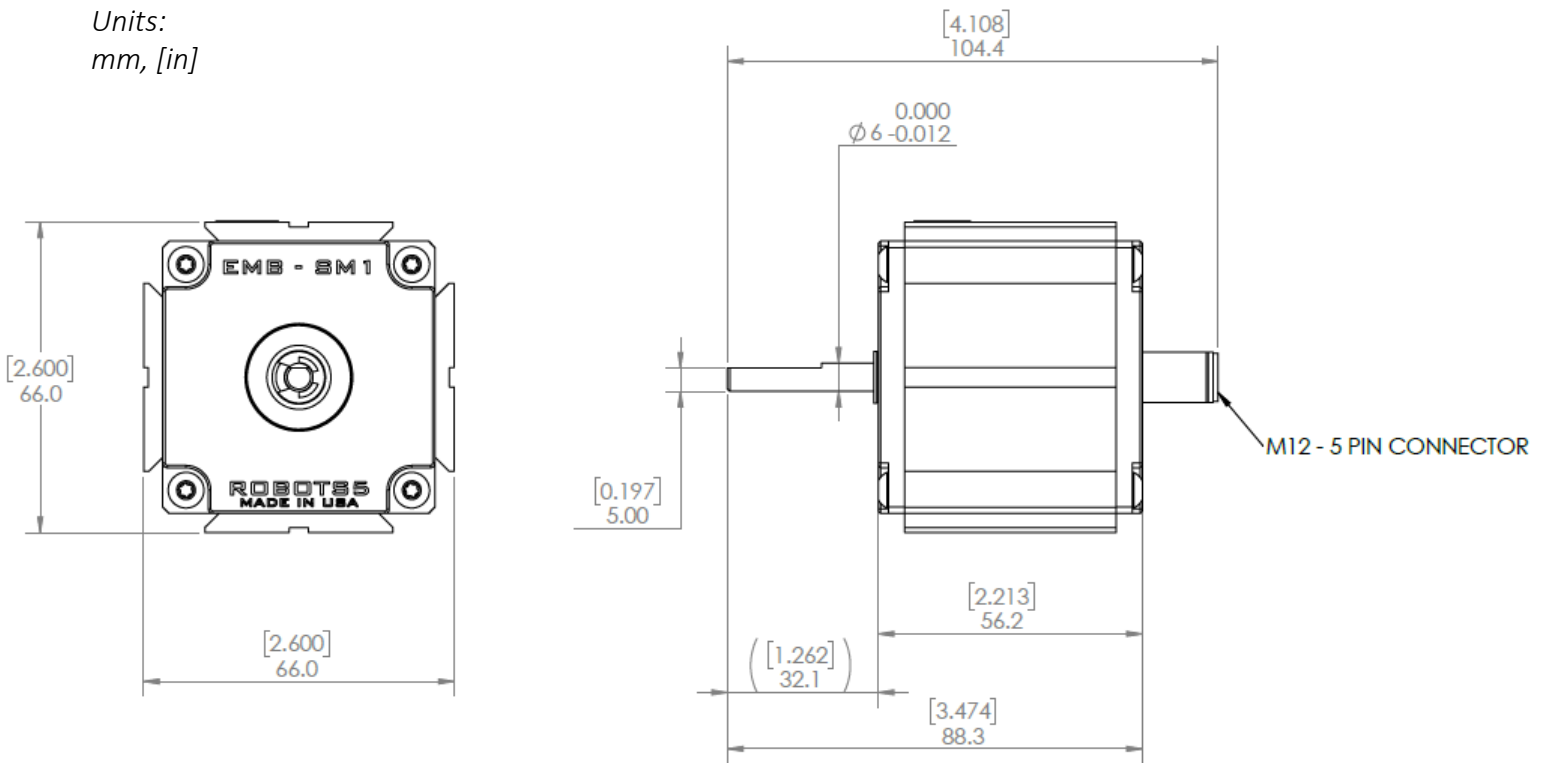

Figure 3: EMB-SM1, general dimensions

Note the shaft tolerance. Never press fit components to the shaft.

The dovetail profile matches the XT66 66mm optical construction rails from Thorlabs.

There are several mounting options to interface with the dovetail, including XT66C4, XT66C2, and XT66P3 from Thorlabs.

The standard cycles per revolution (CPR) for the EMB-SM1 is 2048 CPR. In quadrature mode, the encoder has a resolution of 8192 counts per revolution.

We can also supply the EMB-SM1 module with different CPR counts, if your application requires (ranging from 32 CPR to 5000 CPR).

This encoder offers 2 channel quadrature TTL squarewave outputs. In addition, it has an index channel.

Table 3 describes the electrical specifications:

| PARAMETER | MIN. | TYP. | MAX. | UNITS | CONDITIONS |
|----------------------------|------|------|------|-------|--|
| Supply Voltage | 4.5 | 5.0 | 5.5 | V | |
| Supply Current | 27 | 33 | | mA | CPR < 500, no load |
| | 54 | 62 | | mA | CPR ≥ 500 and < 2000, no load |
| | 72 | 85 | | mA | CPR ≥ 2000, no load |
| Low-level Output | | 0.5 | | V | I _{OL} = 8mA max., CPR < 2000 |
| | | 0.5 | | V | I _{OL} = 5mA max., CPR ≥ 2000 |
| | 0.25 | | | V | no load, CPR ≥ 2000 |
| High-level Output | 2.0 | | | V | I _{OH} = -8mA max. and CPR < 2000 |
| | 2.0 | | | V | I _{OH} = -5mA max. and CPR ≥ 2000 |
| | 4.8 | | | V | no load and CPR < 2000 |
| | 3.5 | | | V | no load and CPR ≥ 2000 |
| Output Current Per Channel | -8 | 8 | | mA | CPR < 2000 |
| | -5 | 5 | | mA | CPR ≥ 2000 |
| Output Rise Time | 110 | | | nS | CPR < 2000 |
| | 50 | | | nS | CPR ≥ 2000, ± 5mA load |
| Output Fall Time | 100 | | | nS | CPR < 2000 |
| | 50 | | | nS | CPR ≥ 2000, ± 5mA load |

Table 3: Encoder electrical data, from US Digital

Connections

Figure 4 and Table 4, show the pin out of the connector:

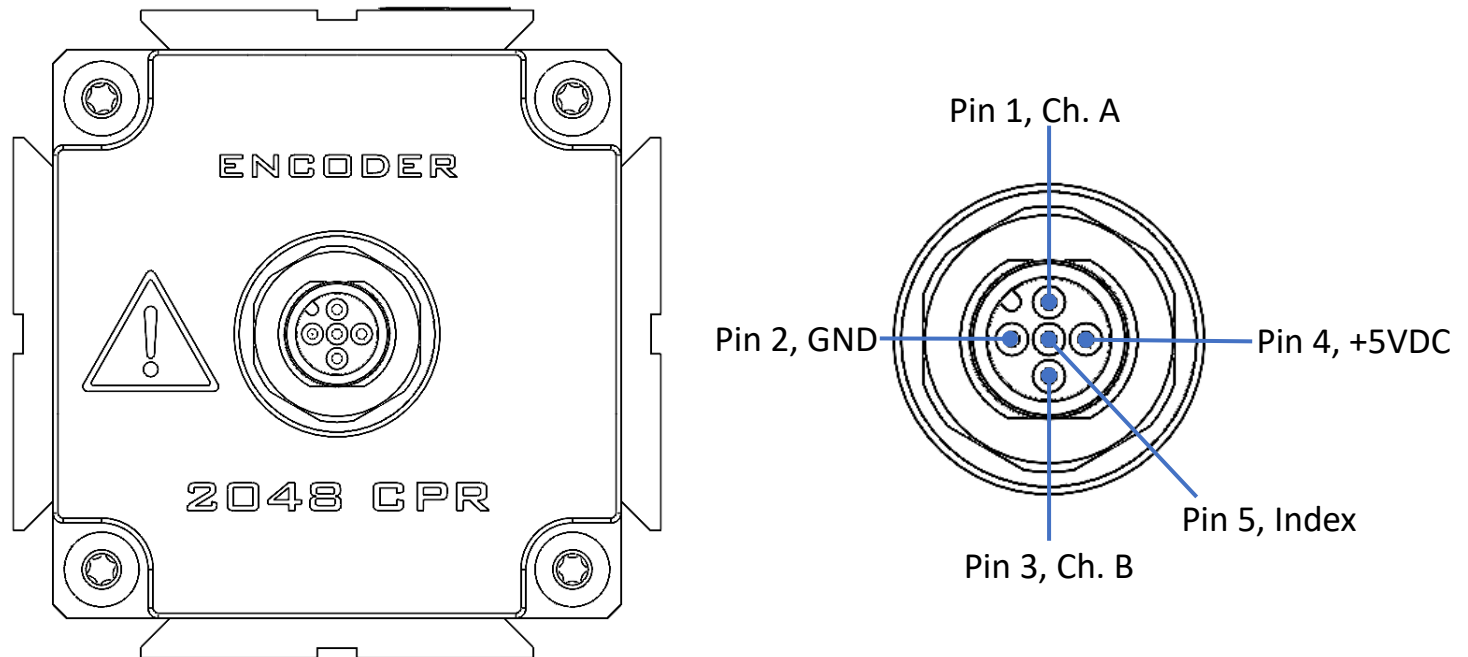

Figure 4: EMB-SM1, pin out

| Pin | Signal | Wire Color ¹ |
|-----|--------|-------------------------|
| 1 | Ch. A | Brown |
| 2 | GND | White |
| 3 | Ch. B | Blue |
| 4 | +5VDC | Black |
| 5 | Index | Gray ² |

Table 4: Encoder pin out

¹ = for Murrelektronik cables

² = or green

Connection to the EMB-SM1 is made through the Murrelektronik M12-5 pole connector. This is a standard industrial connector type.

There are several options for cables, including:

| Murrelektronik PN | Feature |
|--------------------------|---|
| 7000-40041-0250100 | M12 axial Male to M12 axial Female, 5-pole, length 1m |
| 7000-40041-0250300 | M12 axial Male to M12 axial Female, 5-pole, length 3m |
| 7000-12241-0250300 | M12 axial female to pigtail, 5-pole, length 3m |
| 7000-12361-0250300 | M12 right-angle female to pigtail, 5-pole, length 3m |
| 4-Pole Cables | |
| 7000-40021-0240100 | M12 axial Male to M12 axial Female, 4-pole, length 1m |
| 7000-40021-0240300 | M12 axial Male to M12 axial Female, 4-pole, length 3m |
| 7000-12221-0240200 | M12 axial female to pigtail, 4-pole, length 2m |
| 7000-12341-0240200 | M12 right-angle female to pigtail, 4-pole, length 2m |

Table 5: Cable options

Note, using a 4-pole cable won't supply the Index signal, since the center pin of the 5-pole connector won't be connected.

The maximum cable length allowed, to keep a good signal integrity is 3m. We recommend using a shorter cable if your application allows.

If you are using a pigtail option cable, making an incorrect connection or shorting the leads will likely permanently damage the module.

Have questions or need additional support?

Contact us at:

Web: www.robots5.com

Email: info@robots5.com

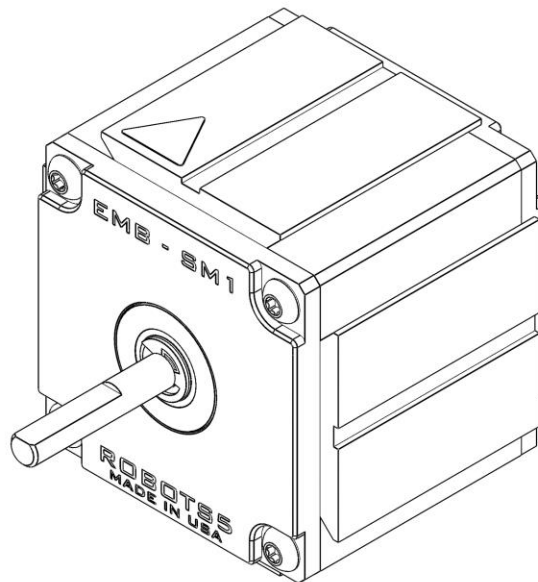

ROBOTS5