

ROBOTS5

ELECTRO-MECHANICAL BREADBOARD (EMB) LM2 USER MANUAL



Version 2.10 - Apr. 2024

ROBOTS5 LLC, USA



Disclaimer

- Be sure to read this document carefully and fully understand it, before using this product
- Be sure to read the “EMB Safety Document” carefully and fully understand it, before using this product
- Robots5 LLC is not responsible for any damage or injury caused by misuse, misunderstanding, or abuse of this product
- The user is solely responsible for the implementation of the controller and safety system used with our products
- This document was generated and completed to the best ability of Robots5 LLC. The information on this manual are presented in good faith and believed to be correct however, Robots5 LLC makes no warranties as to the completeness or accuracy of the information
- Never use our products in any application where failure of the product could result in personal injury. Failure to comply with these instructions could result in death or serious injury
- This equipment should not be used by inexperienced users, unless if they are under close supervision of experienced users. Safety operation must be ensured by experienced users
- Robots5 LLC reserves the right to make changes to this document or to the products described herein without further notice
- Make sure to always use the latest version of this document

Contact Information:

Email: info@robots5.com

Website: www.robots5.com

Location: Melbourne, FL USA

© 2024 Robots5 LLC., All Rights Reserved.



Safety

- If improperly used, EMB can cause injury or death
- Never touch any moving parts! Always stay clear from gears, sprockets, belts, chains, linkages, and any components in motion
- Never place fingers or hands between moving components and hard stops
- Follow all information and recommendations from this document and from the “EMB Safety Document”
- Do not disassemble or modify this device
- Responsible use of EMB is crucial to prevent dangerous conditions
- Make sure to disconnect power when handling this device
- Only use this device in indoor applications, with no water/oil splash or contact. Never operate EMB near explosive gases or flammable liquids
- Treat this device with care, it is a precision unit. Do not throw, hit, or drop it
- If you notice the unit getting warm or hot or making abnormal noises or vibrations, or sense smoke, immediately stop all motion and turn the power completely off. Assess the situation to completely understand the issue before attempting to resume operation
- Do not operate outside the specifications of the unit



Fingers may break or get amputated if caught in moving parts!

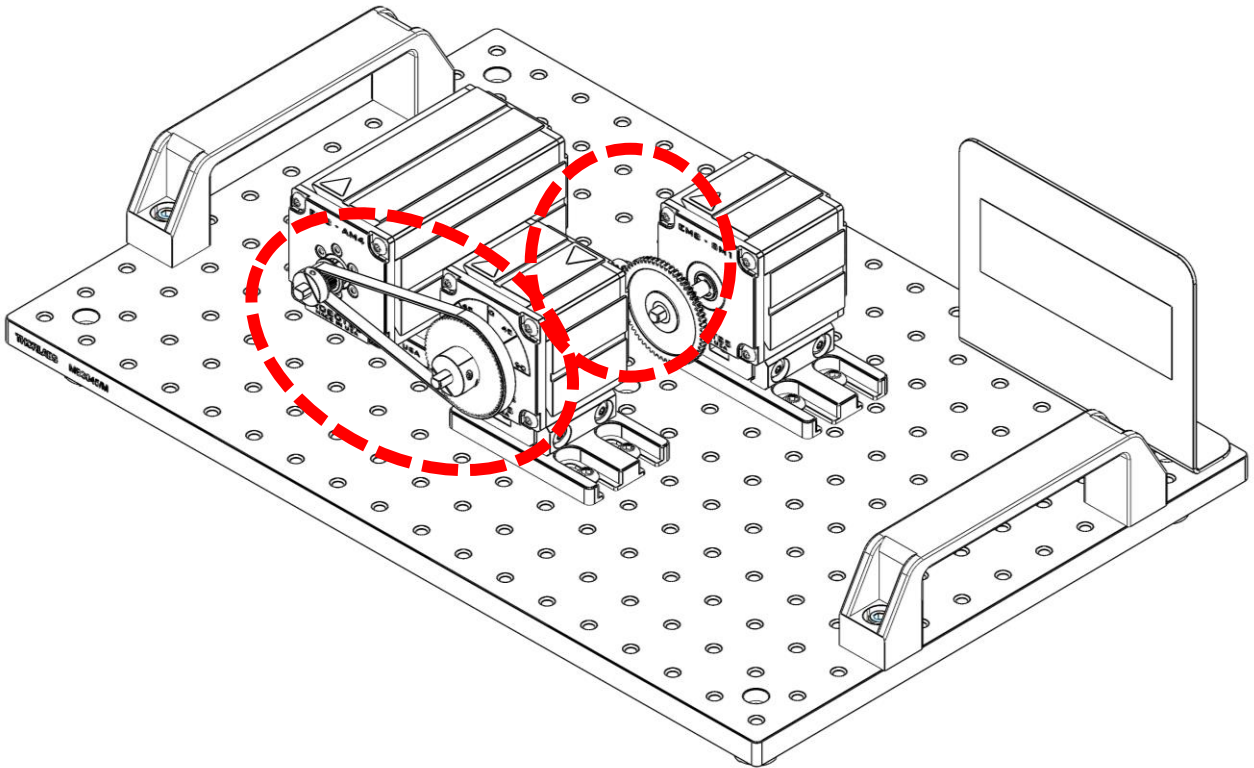

ALWAYS KEEP HANDS AWAY FROM MOVING PARTS!

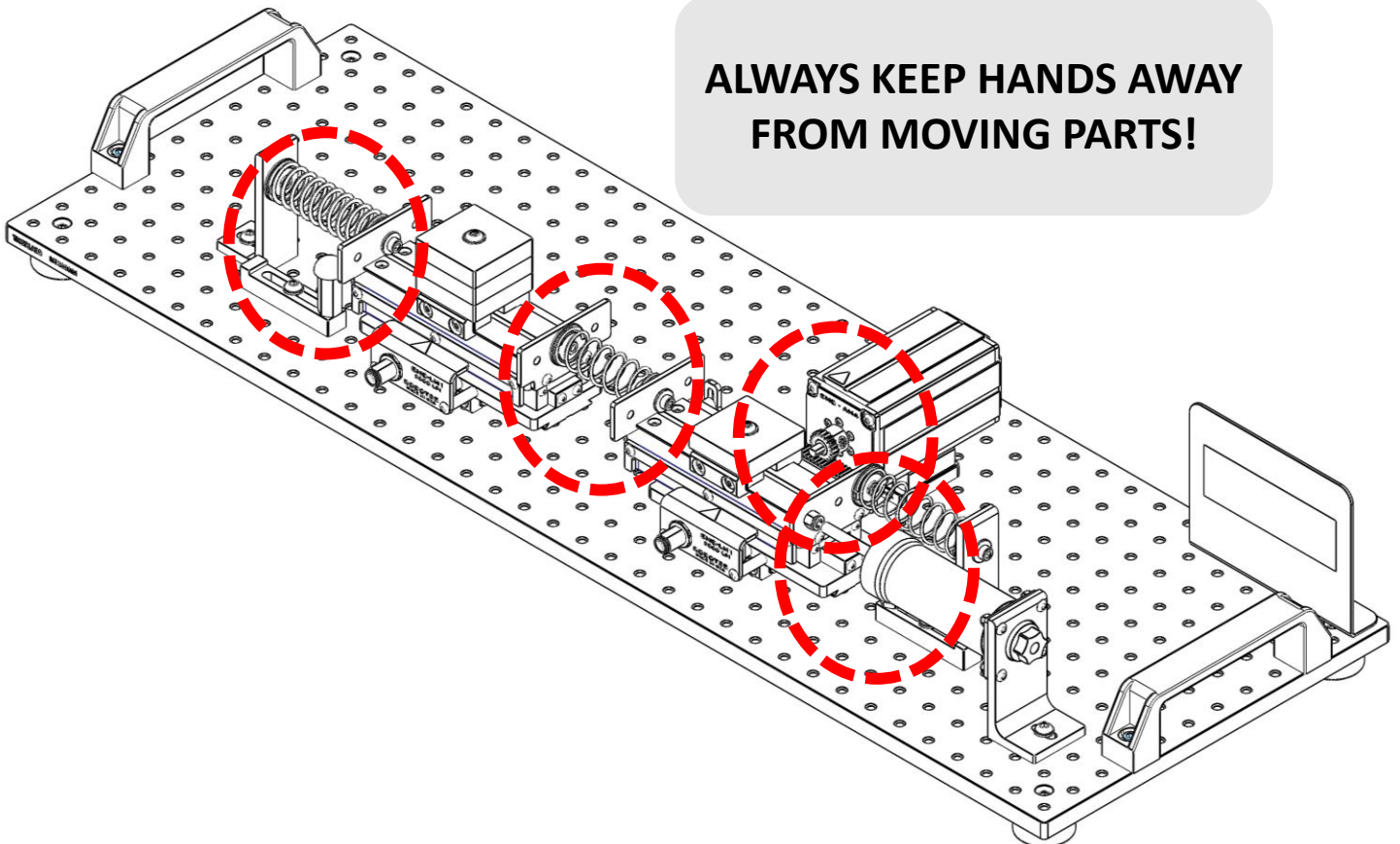

Introduction

The EMB-LM2 is a linear slide module.

This module is designed to interface with other EMB modules via components mounted to the dovetails and side/front/rear tapped holes. Examples of components that can be mounted to the carriage via the tapped holes include the rack attachment, belt attachment, cam attachment, and brake attachment. Examples of components that can be mounted to the carriage via the dovetail include the pendulum attachment, dovetail clamp mount, and accelerometer module.

The anodized aluminum body of the EMB-LM2 module relies on a dovetail approach for precision locating and firmly securing to breadboard or dovetail rail by the use of a clamp.

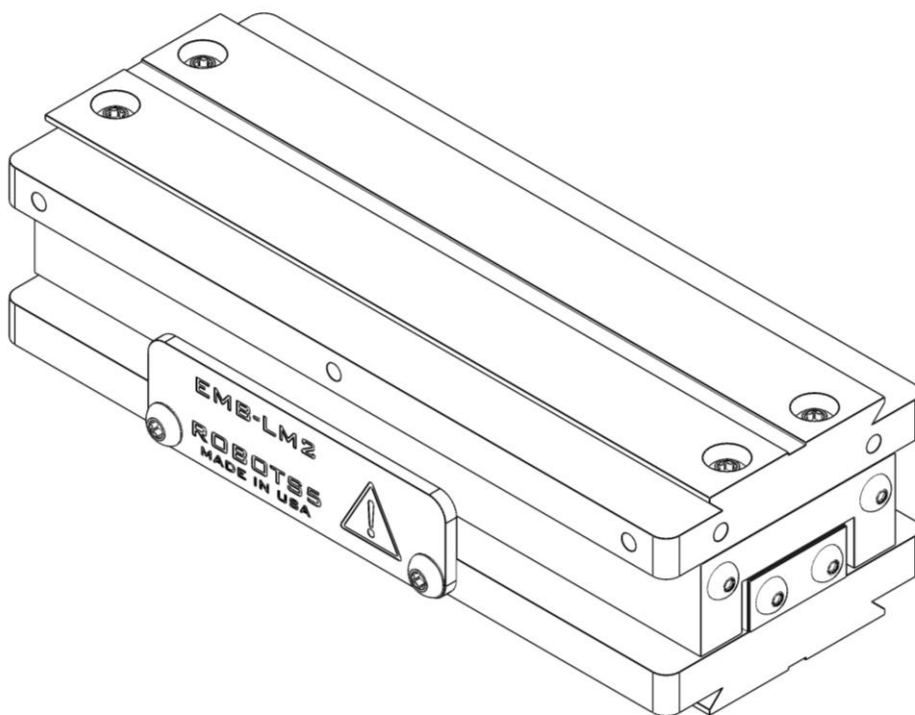

Figure 1: EMB-LM2 Module

The key features of the EMB-LM2 are presented bellow:

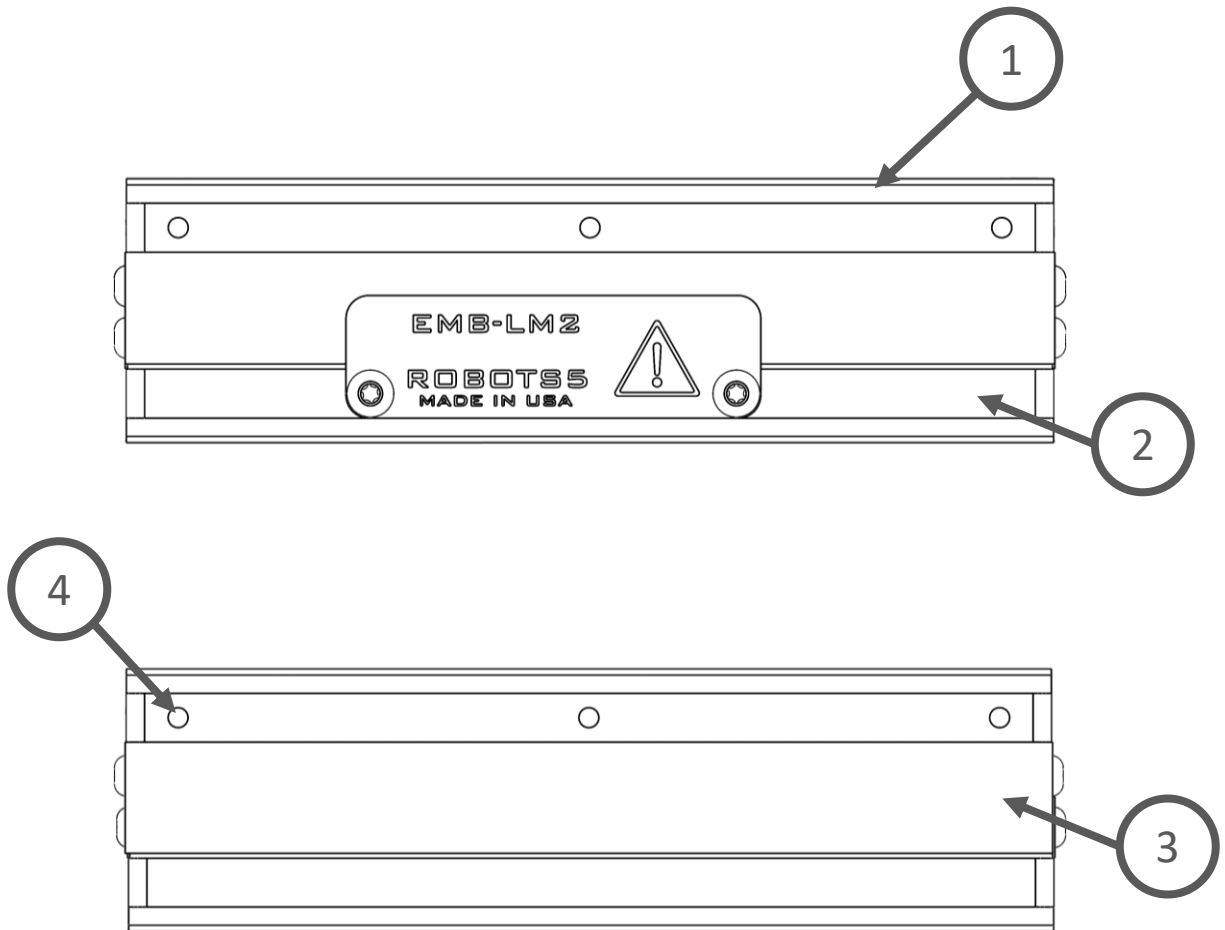

Figure 2: EMB-LM2, front and rear views

Item	Feature
1	Carriage dovetail (moving)
2	Base dovetail (fixed)
3	Low friction ball slide
4	M4x0.7 mounting holes for attachments, 10 total

Table 1: Key features of the EMB-LM2

Specifications

The EMB-LM2 relies on a low friction ball.

Table 2 describes the linear slide mechanical data.

Parameter	Value	Units
Mechanical Travel	100	mm
Mechanical Travel	Continuous	-
Max. Load	250	N
Accuracy ¹	0.013	mm/25mm of travel
IP Rating	IP40	-
Body Material	Aluminum	-
Friction Coefficient ¹	0.003	-
Weight	0.87	kg
Carriage weight (moving)	0.50	kg

Table 2: EMB-LM2 mechanical data

¹ = provided by bearing manufacturer

Figure 3, shows the general dimensions of the module:

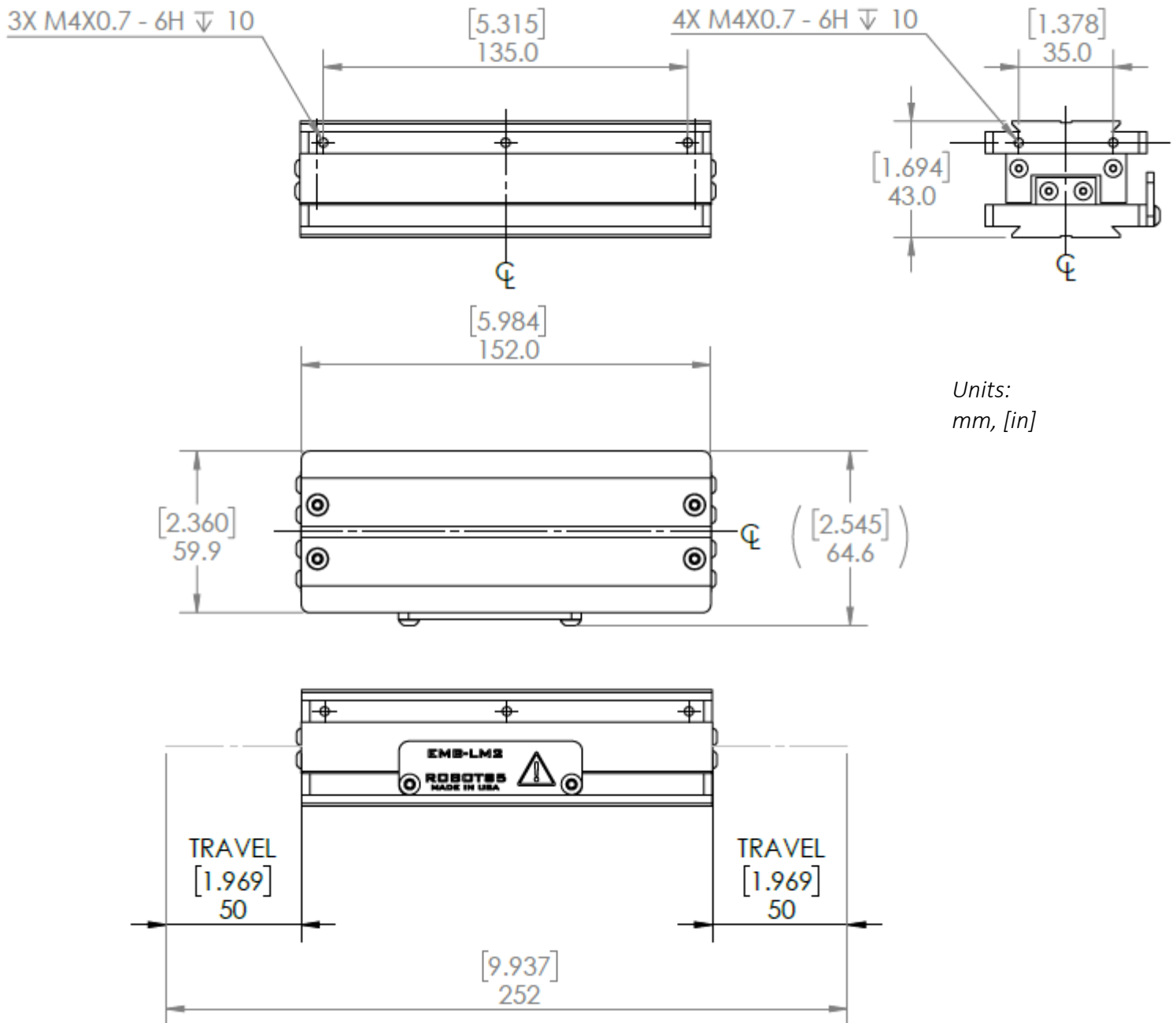

Figure 3: EMB-LM2, general dimensions

The dovetail profile matches the XT66 66mm optical construction rails from Thorlabs.

There are several mounting options to interface with the dovetail, including XT66C4, XT66C2, and XT66P3 from Thorlabs.

The carriage has a total of ten M4x0.7 tapped holes for the user to mount attachments. There are 3 on the front side of the module, 3 on the rear side, and 2 on each side.

End plates can be mounted on the sides of the modules, to connect springs, dampers, and other mechanisms.

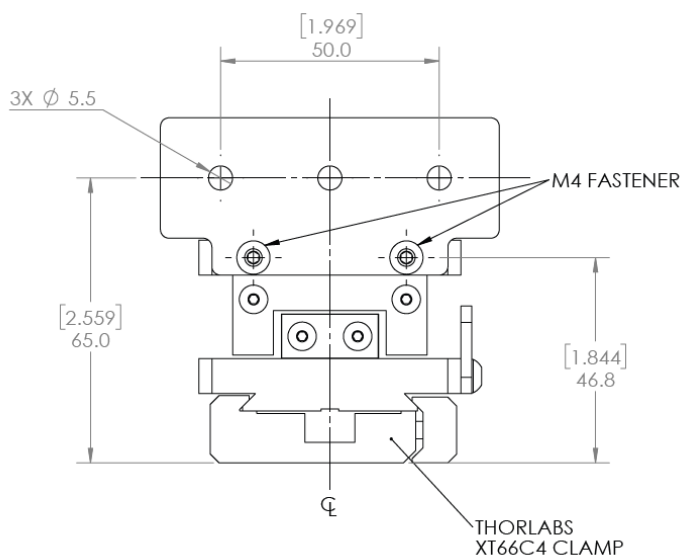

Figure 4: EMB-LM2, end plate dimensions

The internal hard stops of the linear bearing are designed simply to prevent the bearing balls from falling out, they are not designed to handle impacts. Impacts in the internal hard stop will result in permanent damage to the module.

The user must provide an external hard stop to properly constraint end of travel motion, for both sides. We recommend at least 10 millimeters of buffer, between the internal hard stop and the external hard stop.

The contact surface must be compliant (for instance, rubber) so the impact doesn't damage the contact surfaces of the EMB-LM2 module and external hard stops. Robots5 offers hard stops with adjustable mounts to accommodate plant designs.

Have questions or need additional support?

Contact us at:

Web: www.robots5.com

Email: info@robots5.com

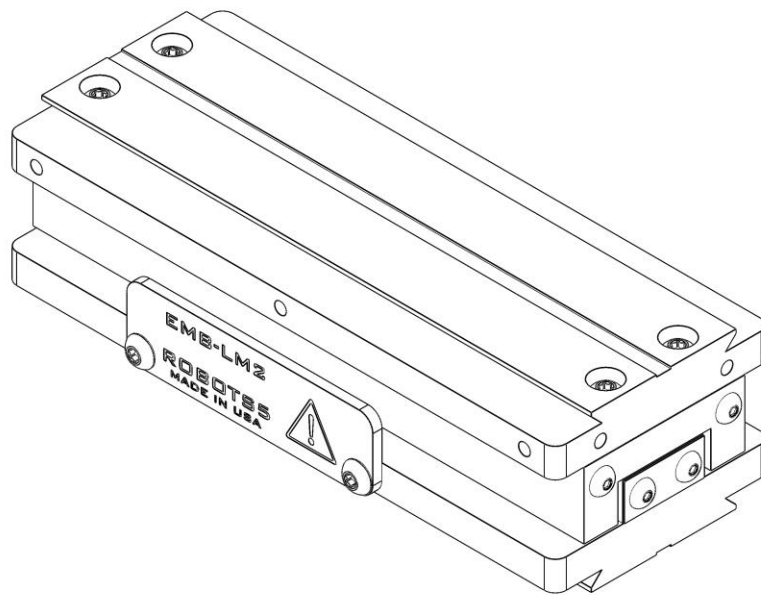

ROBOTS5